

MiniVol Portable Air Sampler

Operation Manual

Airmetrics
2121 Franklin Boulevard, #9
Eugene, OR 97403
U.S.A.

PHONE: 541. 683.5420
FAX: 541. 683.1047

E-mail: sales@airmetrics.com
www.airmetrics.com

Notice:

Information in this manual is subject to change without notice and does not represent a commitment on the part of Airmetrics, which reserves the right to make changes in construction, design, specifications, and/or procedures that may not be reflected in this manual.

Printing History

Manual Version 1.0 - October, 1992, applies to Sampler Models 3.x
Manual Version 1.0a - November, 1992, applies to Sampler Models 3.x
Manual Version 1.1 - June, 1993, applies to Sampler Model 4.0
Manual Version 1.1a - January, 1994, applies to Sampler Model 4.0
Manual Version 1.2 - December, 1994, applies to Sampler Model 4.0
Manual Version 1.2a - July, 1996, applies to Sampler Model 4.1
Manual Version 4.2 - May, 1997 applies to Sampler Model 4.2
Manual Version 4.2a - February, 1998 applies to Sampler Model 4.2
Manual Version 4.2b - December, 2000 applies to Sampler Model 4.2
Manual Version 4.2c - June, 2001 applies to Sampler Model 4.2
Manual Version 4.2d - March, 2006 applies to Sampler Model 4.2

Table of Contents

1	INTRODUCTION	1
	Principles of Operation	1
	Particulate Matter Sampling Mode	1
	Integrated Gas Sampling Mode	2
2	GETTING STARTED	3
	Inspecting Components	3
	Charging Batteries	3
	Connecting Sampler Body and Battery Pack	3
	Removing Pump and Timer Assembly	4
	Turning the Sampler On/Off	4
	Programming the Timer	5
	Setting the Real-Time Clock	5
	Setting the On/Off Times	5
	Setting the Timer to "On," "Auto," and "Off" Modes	6
	Checking for Leaks	6
3	CONTROLS AND ADJUSTMENTS	7
	All Operating Modes	7
	Elapsed Time Totalizer	7
	Programmable Timer	7
	Flowmeter	7
	Flow Rate Adjustment	7
	12V Battery Power Connector	8
	Low Flow Threshold Indicator	8
	Low Flow Cutoff Indicator	8
	Low Flow Zero & Cutoff Adjustments	9
	Low Battery Indicator	9
	Lo-Flow/Lo-Battery Reset Switch	9
	ON/AUTO/OFF Button	9
	Integrated Gas Sampling Option	10
	Solenoid Valve Output Connectors	10
	Active Solenoid Output Indicators	10
	Manual Sequence Advance Button	10
	Pulse Interval Adjustment	10
	Pulse Duration Adjustment	11
	Power On/Off	11
	Pulse Indicator	11
	Overlap Jumper	11
4	PARTICULATE MATTER SAMPLING	13
	Consumables	13
	Siting Requirements	13
	Attaching the Mounting Cradle	13
	Preparing the Sampler	13
	Flow Rate	15
	Flowmeter Calibration	15
	Preseparator/Filter Holder Assembly	15
	Clean and Grease Impactor	16
	Installing Filters	16
	Preparing the Battery Pack	17
	Battery Charging	17

Changing/Installing Battery Pack on Sampler	17
Other Battery Checks	18
Setting the Desired Sampling Time	18
Particulate Matter Sampling Procedure	18
Particulate Matter Sample Retrieval	19
Exposed Filter	20
Error Conditions	20
Low Battery Indicator ON	20
Low Flow Indicator ON	21
Overriding Low Flow/Low Battery Indicators	21
5 INTEGRATED GAS SAMPLING	23
Consumables	23
Siting Requirements	23
Attaching the Mounting Cradle	23
Preparing the Sampler	23
Operation Modes - Standard Mode or Overlap Mode	24
Adjusting Pulse Frequency and Duration	26
Pulse Interval Adjustment	26
Pulse Duration Adjustment	26
Preparing the Sampler	27
Installing Tedlar® Bags and Attaching Canisters	28
Integrated Gas Sampling Procedure	29
Gas Sample Retrieval	29
6 HARDWARE DESCRIPTION	31
Pneumatic System	31
Pneumatic System Flow Schematic	31
Filter Holder Assembly	31
Flowmeter	31
Flow Control System	31
Electronics System	32
Motherboard	32
Power	33
Programmable Timer	33
Flow Controller Circuit	33
Elapsed Time Totalizer	33
Interconnect Board	33
7 MAINTENANCE	35
Preseparator/Filter Holder Assembly	35
Impactor Cleaning	35
Flow Control System	36
Programmable Timer	36
Battery Pack	36
<i>Cleaning/Inspecting Pump Valves and Diaphragms</i>	36
Cleaning/Inspecting Pump Head Valves	36
8 TROUBLESHOOTING	39

Appendices

A	SAMPLER FLOW RATE CALIBRATION	43
B	QUICK REFERENCE	47
C	WARRANTY POLICY	49
D	REPLACING DAMAGED/DEFECTIVE COMPONENTS	51
E	PARTS LIST	53

List of Figures

Figure 2.1.	Attaching Battery Pack	4
Figure 2.2.	Programmable Timer	4
Figure 3.1.	Sampler Controls and Adjustments	8
Figure 4.1.	Mounted Sampler	14
Figure 4.2.	Tubing Configuration for PM Sampling Mode	15
Figure 4.3.	PM₁₀ Preseparator and Filter Holder Assembly	16
Figure 4.4.	PM_{2.5} Preseparator and Filter Holder Assembly	17
Figure 5.1.	Tubing Configuration for Integrated Gas Sampling Mode	24
Figure 5.2.	Installing Tedlar® Bag	28
Figure 5.3.	Attaching Bag Canisters and Tubing	28
Figure 6.1.	Pneumatic System Flow Schematic	32
Figure 7.1.	Regreasing PM_{2.5} Impactor	35
Figure A.1.	Portable Sampler Calibration Output	44
Figure F.1.	Main Circuit Board Parts Identification.	53
Figure F.2.	Valve Driver Board Parts Identification	55
Figure F.4.	Preseparator and Filter Parts Identification	58
Figure F.5.	Battery Pack Parts Identification	60
Figure F.6.	Integrated Gas Sampling Bag Parts Identification	62
Figure F.7.	Mounting Hardware Parts Identification	64

This page was intentionally left blank..

1 INTRODUCTION

The MiniVol Portable Air Sampler is an ambient air sampler for particulate matter and non-reactive gases. The patented low flow technology used in the MiniVol was developed jointly by the U. S. Environmental Protection Agency (EPA) and the Lane Regional Air Pollution Authority in an effort to address the need for portable air pollution sampling technology.

While not a reference method sampler, the MiniVol gives results that closely approximate reference method air quality data. Both accurate and precise, the battery operated, lightweight MiniVol is ideal for sampling at remote sites or areas without power. In addition, the low cost of the sampler allows a network of MiniVols to be deployed at a fraction of the cost for a similar reference station network.

The MiniVol features a 7-day programmable timer, a constant flow control system, an elapsed time totalizer, rechargeable battery packs, and all-weather PVC construction. The MiniVol can be configured to sample for just particulate matter, just gases, or both simultaneously.

Principles of Operation

The MiniVol Portable Air Sampler is basically a pump controlled by a programmable timer which can be set to make up to six "runs" within 24 hours or throughout a week. When used outdoors it may be hung from a bracket mounted on a variety of structures—utility poles, trees, fence posts, etc.

The sampler is equipped to operate from either AC or DC power sources. In the DC operational mode, the sampler operates from a battery pack, thus making the sampling site independent of line power. In the AC mode the battery pack is connected to line power and mated to the sampler unit. This configuration charges the battery while using AC power. The MiniVol comes with two battery packs to accomplish continuous field sampling. A charged battery pack is capable of operating the sampler for up to 24 sampling hours on a single charge.

The sampler is equipped with two "fault circuits":

- A **low battery circuit** automatically shuts the sampler down should the rechargeable lead-acid battery fail to supply sufficient voltage (below 10.3 volts) to the pump. This feature protects the battery which could be damaged if used continuously at low voltage. A "low-battery" indicator lights to alert the operator of this condition.
- A **low flow circuit** monitors the flow rate. Should excessive accumulation of particulate matter or some restriction in the tubing cause the air flow to fall below a specified rate, the sampler shuts down and a "low flow" indicator lights to alert the operator.

An **Elapsed Time Totalizer** linked in parallel with the pump records the total time in hours of pump operation.

PARTICULATE MATTER SAMPLING MODE

In the particulate matter (PM) sampling mode, air is drawn through a particle size separator and then through a filter medium. Particle size separation is achieved by impaction. Critical to the collection of the correct particle size is the correct flow rate through the impactor. For the MiniVol, the actual volumetric flow rate must be 5 liters per minute (5 lpm) at ambient conditions. To assure a constant 5 lpm flow rate through the size separator at differing air temperatures and atmospheric pressures, the sampler must be adjusted for each sampling project.

NOTE: The terms SIZE SEPARATOR, PRESEPARATOR and IMPACTOR are used interchangeably in this manual.

Impactors are available with a 10 micron cut-point (PM₁₀) and a 2.5 micron cut-point (PM_{2.5}). Operating the sampler without an impactor allows for collection of total suspended particulate matter (TSP).

The inlet tube downstream from the filter takes the air to the twin cylinder diaphragm pump. From the pump, air is forced through a standard flowmeter where it is exhausted to the atmosphere inside the sampler body.

The programmable timer will automatically turn the pump off at the end of a sampling period. The sampler must then be serviced and set up for the next sampling period. Servicing includes removing the sampler from its hanging bracket, removing the filter holder with the exposed filter inside from the sampler, and attaching a new filter holder with a fresh filter. The battery pack is also changed at this time.



The sampling technique used by the MiniVol is a modification of the PM₁₀ reference method described in the U. S. Code of Federal Regulations (40 CFR part 50, Appendix J). Under this criteria, a PM₁₀ sampler must have: 1) a sample air inlet system to provide particle size discrimination, 2) a flow control device capable of maintaining a flow rate within specified limits, 3) means to measure the flow rate during the sampling period, and 4) a timing control device capable of starting and stopping the sampler.

The Airmetrics MiniVol Portable Air Sampler meets all of these specifications. It is equipped with: 1) an inlet impactor capable of separating particulate matter to $\leq 10 \mu\text{m}$, 2) a flow control device which will maintain a specified flow rate, 3) a flowmeter to measure the flow rate during the sampling period, 4) an elapsed time meter, and 5) a programmable timer that starts and stops the sampler unattended.

The MiniVol's flow rate is generally less than the flow rates used by reference method devices. The lower rate results in a greater deviation in accuracy at low concentrations of particulate matter where precision can be lost through the handling and weighing of a minute particulate sample. However, at high particulate concentrations the sampler produces results that are precise and comparable to reference method samplers. While the MiniVol's sampling method is not a reference or equivalent method, the data collected by the sampler still serves as a useful supplement to data generated by PM₁₀ reference methods.

INTEGRATED GAS SAMPLING MODE

In the integrated gas sampling mode, the sampler can accommodate one or two bag modules. The bags may be filled one at a time or simultaneously within a programmable period. There are two circuits which control the gas sampling:

1. A tuneable intervalometer, or pulse circuit, determines the rate at which a bag is filled. The circuit sends an electronic pulse to open a solenoid on the valve driver board. The duration of each pulse can be adjusted from approximately 50 to 750 milliseconds. The pulses can also be adjusted for frequency, from one pulse every 15 seconds to continuously on.
2. A bag sequencer determines which of the two bags is being filled during any programmed interval.

While the bags that are supplied with the samplers are made of relatively non-reactive Tedlar® (polyvinyl fluoride), other parts of the air path are made of PVC, polyethylene, silicone rubber, and other substances that are more reactive. Consequently, you should not use the MiniVol to collect gas samples that are to be analyzed for reactive gases like ozone or sulfur dioxide.

In the gas sampling mode, the air that is used to fill the bags is diverted from the normal air path just before the air is vented into the sampler case—at the end of the air path. Because of this, you may simultaneously collect a PM sample (the filter holder is situated at the beginning of the air path) while collecting a gas sample.

2 GETTING STARTED

Inspecting Components

When purchased, a standard MiniVol comes packed in two plastic carrying cases, one containing two battery packs and a transformer, the other containing the sampler and two preseparator/filter holder assemblies. A mounting cradle is shipped outside of the carrying boxes. Each sampler includes:

- 1 pump module
- 2 preseparator/filter holder assemblies
- 2 battery packs
- 1 12 VDC battery charger
- 2 plastic carrying cases
- 1 mounting cradle

If you ordered the Integrated Gas Sampling option, you will also receive:

- 1 valve driver board (pre-installed on back of main circuit board)
- 4 collection canisters, each with a 6-liter Tedlar® bag
- 1 24-inch bale bar with removable end caps
- 1 bale handle

Every order also includes an Operation Manual and a packet of spare parts.

On receipt, visually inspect the contents of the cases to account for all components. Compare the equipment delivered with the enclosed packing slip. Notify Airmetrics of any missing or damaged equipment (see Appendix D).

Charging Batteries

1. Connect the charging plug of the battery charger to the charging jack on the first battery pack.
2. Plug the transformer into a fused AC outlet.
3. The LED on the top of the battery charger will light indicating that the battery is being charged. When this light is green the battery is charged but continues to receive a “trickle” charge as long as it is plugged into the charger. A fully discharged battery requires at least 12 hours to be completely recharged.
4. If the battery will be used frequently, leave it plugged into the charging transformer until its next use. Leaving the battery plugged in allows it to receive a trickle charge maintaining the battery in a fully charged state.

Connecting Sampler Body and Battery Pack

1. Lift the sampler over the battery pack and carefully insert the banana pins extending from the sampler bottom into the sockets on the top of the battery pack. The pins are unevenly spaced and can fit only one way—**the pin closest to a latch on the sampler body inserts into the odd colored receptacle on the battery pack** (see Figure 2.1).
2. Clamp the two latches.

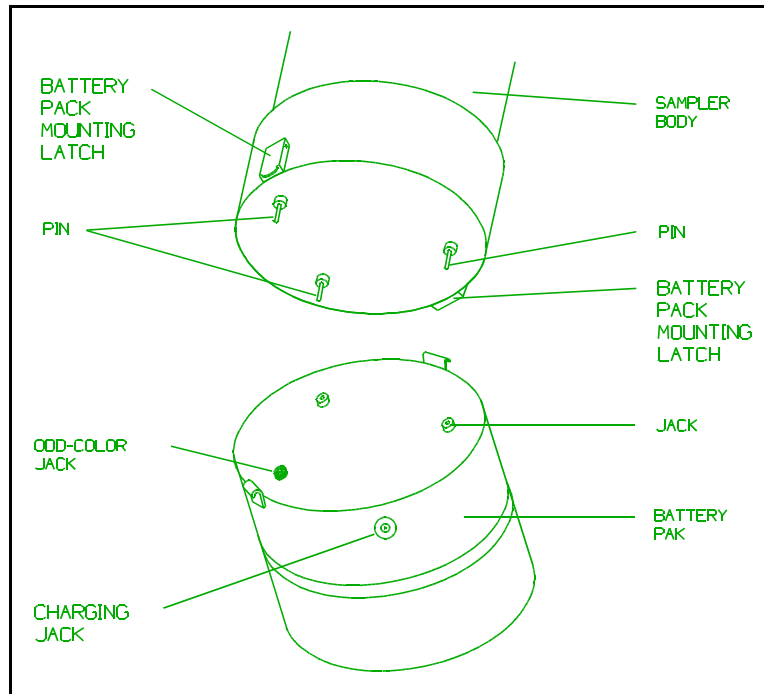

Figure 2.1. Attaching Battery Pack

Removing Pump and Timer Assembly

The two stainless steel snap buttons secure the 6" diameter top cap to the sampler body. To remove the pump and timer assembly from inside the sampler body do the following:

1. While depressing the snap buttons lift the 6" diameter top cap. This process is more easily performed while the sampler is attached to a battery.
2. Since the short connecting wire does not allow the assembly to be removed from the sampler body beyond a few inches, rest the assembly on the edge of the sampler casing by using the triangular mount stand. Leave the battery attached to the sampler to stabilize the unit, and hold the assembly by the top cap. Do NOT grasp the circuit board.

Turning the Sampler On/Off

The **ON/AUTO/OFF** button on the Programmable Timer allows the operator to manually turn the sampler on or off (or to place it in the "Auto" mode in which it is controlled by programmed on/off sequences). As the ON/AUTO/OFF button is pressed, a bar at the lower edge of the LCD display moves horizontally over the words "On", "Auto" and "Off" which are printed on the timer case (see Figure 2.2).

With the sampler attached to a charged battery pack, press the ON/AUTO/OFF button until the bar is above the "On" legend. The red power indicator (to the right of the ON/AUTO/OFF button) should light and the pump motor should start.

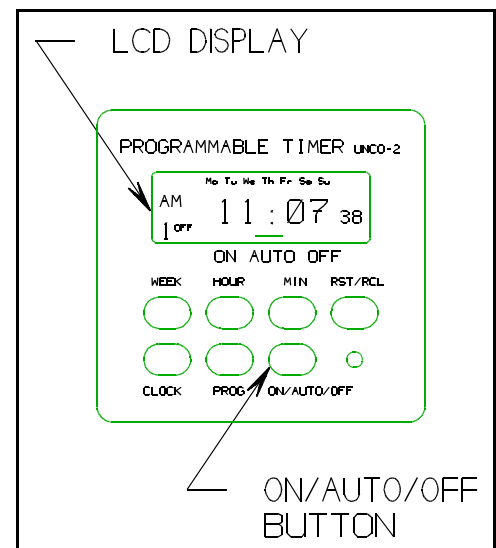

Figure 2.2. Programmable Timer

If the Timer display does not respond, check the single AA battery on the circuit board. Removing the battery resets the timer and clears the display.

While the sampler is running, press the ON/AUTO/OFF button, until the bar is over the OFF legend. The power indicator light will go off and the pump will stop running.

Programming the Timer

The Programmable Timer can be set to run up to six on/off cycles within a 24 hour period, as well as to run for separate time periods on separate days within a 7-day period. To set the timer, first set the real-time clock to establish the correct time frame in which the cycles are to run. Next, enter the on/off times at which the programmed cycles are to begin and end. Finally, set the timer to "Auto" mode.

Refer to Figure 2.2 when performing the following procedures.

SETTING THE REAL-TIME CLOCK

1. DAY SET: Hold down the CLOCK button and press the WEEK button until the correct day appears at the top of the display.
2. TIME SET (Hour): Hold down the CLOCK button and press the HOUR button until the display indicates the correct hour. You may have to cycle through the hours twice to obtain the proper AM or PM (on the left side of the display). Seconds will automatically reset to zero.
3. TIME SET (Minutes): Hold down the CLOCK button and press the MIN button until the display indicates the correct minutes. Seconds will automatically reset to zero.

SETTING THE ON/OFF TIMES

1. Press the PROG button once. 1^{ON} will appear near the lower left corner of the display indicating that the power-on time for the first cycle is ready to be programmed.
2. Press the HOUR and MIN buttons to enter the power-on time for the first cycle.
3. Press the WEEK button to select the desired day. The days appear along the top of the display. Continuously pressing the WEEK button will sequentially display "Mo Tu We Th Fr Sa Su", "Mo", "Tu", "We", "Th", "Fr", "Sa", "Su", "Mo Tu We Th Fr", "Sa Su" and finally back to "Mo Tu We Th Fr Sa Su". When more than one day is displayed, these days will all have the same power-on time.
4. After you have entered the power-on time and date for the first cycle, press the PROG button. 1^{OFF} now appears on the display to indicate that the power-off time for the first cycle is ready to be programmed. Repeat steps 2 and 3 to enter the desired power-off time.



The power-off time does not have to occur on the same day as the on time. In this way, sampling may start on one day and end on the next day.

5. Press the PROG button again. 2^{ON} appears on the display to indicate that the second power-on time is ready to be programmed. Repeat steps 2 to 4 to enter the remaining power-on/power-off times (up to 6 on/off times).

6. Press the PROG button to step through the times you entered to make sure they are correct. Press the RST/RCL button to disable (ReSeT) or reactivate (ReCaL) any time entries. When you disable a particular power-on/off entry, four dashes will appear instead of the time. When you reactivate an entry, it will return to the values that were set before you performed a reset.



Be sure to clear all unwanted time entries prior to sampling in the AUTO mode. Both ON and OFF entries need to be disabled for the unwanted programs to be inactive.

7. Press the CLOCK button to return to the real-time clock display.
8. Press the ON/AUTO/OFF button until the bar is positioned above the "OFF" legend.

SETTING THE TIMER TO "ON," "AUTO," AND "OFF" MODES

The ON/AUTO/OFF button is used to manually turn the sampler on or off, or to place it in the "Auto" mode. A bar on the lower edge of the LCD display moves from "Off" to "Auto" to "On" as the button is pressed. In the "Auto" mode the sampler is controlled by the programmed on/off sequences.

- To manually turn the sampler ON, press the ON/AUTO/OFF button until the bar on the lower edge of the display is above the "ON" legend. The pump will start and the power indicator will light.
- To manually turn the sampler OFF, press the ON/AUTO/OFF button until the bar is above the "OFF" legend.
- To set the timer to "AUTO" mode in which the sampler will be automatically controlled by programmed sequences, first turn the sampler OFF. Then press the ON/AUTO/OFF button until the bar is above the "AUTO" legend.

Checking for Leaks

To check for leaks, remove the preseparator/filter holder assembly and cover the air inlet at the top of the sampler body with the palm of the hand while the pump is running. The ball in the flowmeter should drop immediately to zero and remain there without movement. If it does not, a leak exists somewhere in the hoses and fittings between the inlet and the flowmeter. Leaks on the *inlet* side of the pump are especially critical, since flow measurement will not accurately reflect the amount of air passing through the filter. The sampler will be measuring air passing through the filter, *plus* whatever air may be entering through the leak.

- Verify that all push-on hose fittings are secure.
- Check the screw fittings attached to the pump. These must be screwed in securely. Unlike pipe threads these fittings "seat" into their connecting socket. Do NOT attempt to tighten these fittings with a wrench, since too much pressure could break them. If any appear loose, tighten by hand to a "finger snugness."
- Check the push-on hose fitting beneath the 6" white cap just below the quick connect.

3 CONTROLS AND ADJUSTMENTS

All Operating Modes

The following controls (see Figure 3.1) are used to set the operation of the MiniVol in both the particulate matter sampling mode and the gas sampling mode.

ELAPSED TIME TOTALIZER

The Elapsed Time Totalizer displays the total number of hours, with a resolution of tenths of hours, that the pump has run. The totalizer accumulates time only while the pump is running. It cannot be reset to zero. The total hours should be recorded at the beginning and end of each sampling period.

PROGRAMMABLE TIMER

The Programmable Timer controls the on/auto/off operation of the sampler. The timer allows up to six sampling times to be preprogrammed over twenty-four hours or throughout a week (see "Programming the Timer").

FLOWMETER

The Flowmeter indicates the flow rate of air through the system in liters/minute. The flow rate is adjusted using the "Flow Rate Adjustment".

The flowmeter readings must be taken from the center of the ball.

FLOW RATE ADJUSTMENT

The Flow Rate Adjustment potentiometer (knob) varies the sampler's flow rate as indicated by the level of the ball (read from the center of the ball) in the flowmeter. Slowly turn the knob until the air flow reaches the desired level. The sampler's Flow Control Circuit will attempt to maintain this flow rate by varying the speed of the pump as particulate matter accumulates on the filter.

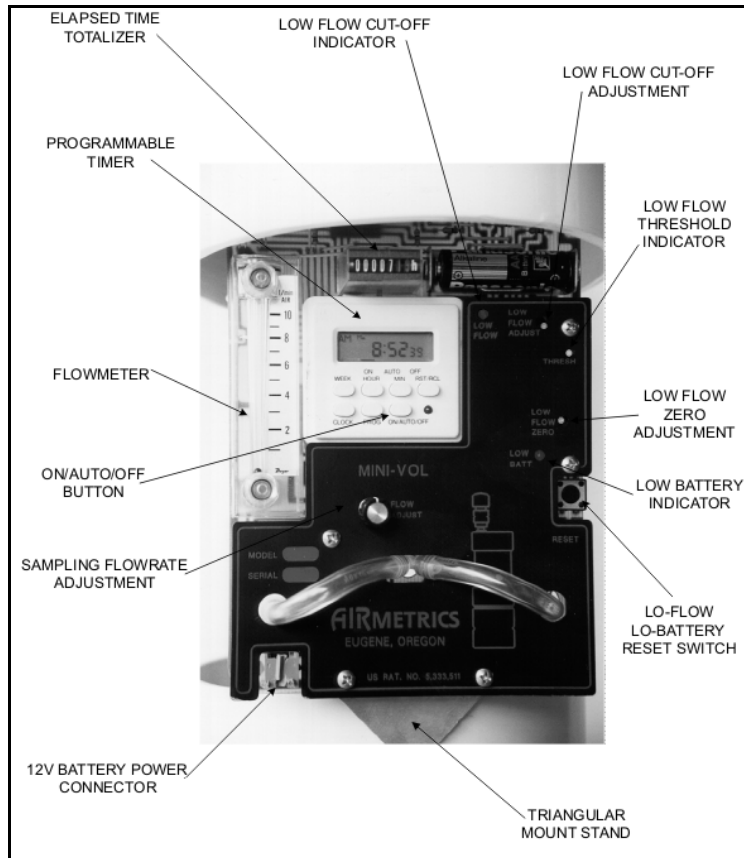

Figure 3.1. Sampler Controls and Adjustments

12V BATTERY POWER CONNECTOR

The 12V Battery Power Connector is a standard phone plug-in jack which conducts power from the battery to the sampler.

LOW FLOW THRESHOLD INDICATOR

The Low Flow Threshold Indicator light is activated when the flow sensor determines that the air flow rate has dropped some increment below the flow rate that was set using the Flow Rate Adjustment and when the Flow Control Circuit can no longer maintain the desired flow rate. The size of the increment is adjusted with the Low Flow Coarse and Fine Adjustments.

NOTE: This light is on whenever the sampler is connected to a power source but is not operating.

LOW FLOW CUTOFF INDICATOR

If the Low Flow Threshold Indicator is lit for an extended period of time (several seconds), the flow sensor will shut off the sampler's pump and turn on the Low Flow Cutoff Indicator light. The red light will remain lit to alert the operator that the sampling was aborted because air flow could not be maintained at the desired rate. The pump is turned off because the cut-point of the PM size selective inlet is determined by the air flow rate through the inlet. For the inlet to have constant particle size cut-point, it is necessary to maintain a constant flow rate throughout the sampling period.

When a low flow cutoff condition arises, the sampler can be restarted only by pressing the "Reset Switch" (see Figure 3.1).

LOW FLOW ZERO & CUTOFF ADJUSTMENTS

The Low Flow Zero and Cutoff Adjustments set the increment below the desired flow rate at which point the sampler will shut off. Two potentiometers are used to set the cutoff point: the Low Flow Zero Adjustment, with a range of adjustment of approximately 0% to 100% below the desired rate, and the Low Flow Cutoff Adjustment, with an approximate 0% to 20% adjustment range. In particulate sampling, the desired flow rate is 5 lpm, and the flow rate below which sampling should be terminated is between 4.5 and 4 lpm, a 10 - 20 percent decrease in flow rate.

To set a low flow cutoff 10 - 20 percent below the optimal flow rate:

1. Turn the sampler on.
2. Using the Sampling Flow Rate Adjustment, set the desired optimal flow rate as measured by the Flowmeter.
3. Set the Low Flow Cutoff Adjustment to the zero position (rotated fully counterclockwise).
4. Adjust the Low Flow Zero Adjustment until the Low Flow Threshold Indicator lights dimly but the pump continues to run. If the pump shuts off, turn the Zero Adjustment clockwise and reset with the Lo-Flow/Lo-Battery Reset Switch. At this point the cutoff flow rate is nearly equal to the optimal flow rate.
5. Remembering that the Low Flow Cutoff Adjustment turned fully counterclockwise is equivalent to a 0 percent less cutoff flow rate and a fully clockwise setting ($\approx 180^\circ$ rotation) is equivalent to a 20 percent less cutoff flow rate, turn the Cutoff Adjustment to the position that will yield the desired cutoff flow rate. For example, if the optimal flow rate was set at 5 liters/minute and a cutoff flow rate of 4.5 liters/minute is desired, rotate the Cutoff Adjustment clockwise by 90° .



The absolute low flow cutoff rate can be determined by running the sampler with a variable restrictor (valve) installed in the inlet tubing. Watch the flowmeter while increasing the restriction until the low flow threshold indicator lights. The cutoff flow rate is the rate indicated by the flowmeter just as the indicator light turns on.

LOW BATTERY INDICATOR

When lit, the Low Battery Indicator means that the battery voltage has dropped to a limit too low (10.3 volts) to permit continued operation. When the low voltage limit is reached, the pump shuts off and the low battery indicator turns on and remains to alert the operator. If the pump was not turned off and the battery voltage continued to drop, the battery could be permanently damaged or its life significantly shortened.

When a low battery condition arises, the sampler can be restarted only by pressing the "Reset Switch" (see Figure 3.1).

LO-FLOW/LO-BATTERY RESET SWITCH

The Lo-Flow/Lo-Battery Reset Switch restarts the pump when the system has been shut down due to low flow or low battery voltage conditions.

ON/AUTO/OFF BUTTON

The ON/AUTO/OFF Button manually turns the sampler on, off, or places it in the "Auto" mode. In the "Auto" position, the sampler is controlled by whatever programmed on/off sequences have been entered. A bar on the lower edge of the Programmable Timer's LCD display moves from "On" to "Auto" to "Off" as the button is pressed (see "Programming the Timer" in Section 2).

Integrated Gas Sampling Option

Integrated bag filling is accomplished with a Valve Driver Circuit board that plugs into the auxiliary connector on the back of the sampler motherboard. The Valve Driver Board controls the operation of the two solenoid valves that are mounted on the board. This arrangement allows for collection of one or two bag samples during a user selected sampling period. For example, this option allows for collecting two 4- or 8-hour integrated bag samples.

Functionally, sample gas is supplied to the common inlet port of each normally closed solenoid valve by the constant back-pressure of the flow control system. The sampler pump operates continuously at a pre-set flow rate to purge the system and supply sample gas to the solenoids under pressure. The output port of each normally closed solenoid valve is connected to a bag module. Because the pump is operating continuously during the sampling period, a PM sample may be collected concurrently with the integrated gas samples.

Electronically, the Valve Driver Board interacts with the Programmable Timer on the motherboard to perform two functions: 1) control which solenoid valve is activated, and 2) set the duration and frequency of the "on" time for the active solenoid valve.

A 4-step circular sequencing circuit advances each time the programmable timer on the motherboard is switched from the "Auto" to the "Off" mode. There are four solenoid output connectors with corresponding indicators located in the upper lefthand corner of the board that the solenoid valves can be plugged onto. The indicators show the output that is, or will be, active when the sampler is switched to the "On" mode either manually or by programmed operation. When a solenoid output is active and the sampler is in the "On" mode, a solenoid valve plugged onto the active output pins is opened and closed by a tunable intervalometer circuit. Both frequency and duration of solenoid valve operation are adjustable to allow the user maximum flexibility in controlling the bag filling rate.

SOLENOID VALVE OUTPUT CONNECTORS

The Solenoid Valve Output Connectors connect the solenoid valves to the sequencing circuit.

ACTIVE SOLENOID OUTPUT INDICATORS

The Active Solenoid Output Indicator LED above each Solenoid Valve Output Connector indicates when that set of pins is active. When active the Tunable Intervalometer will open and close the solenoid valve plugged into the corresponding connector.

MANUAL SEQUENCE ADVANCE BUTTON

The Manual Sequence Advance Button allows the operator to select which Solenoid Valve Output Connector will be active when the pump is turned on. The Manual Advance only functions when the pump is off. Each time the pump is turned off, the channel advances automatically.

PULSE INTERVAL ADJUSTMENT

The Pulse Interval (off time) of the circuit is adjustable over a range of 0-15 seconds by a 16-position rotary switch. This switch is located just to the right of the solenoid valve output connectors. Switch positions are marked clockwise 0-9, and continue A-F. The interval between pulses increases in 1-second increments as the switch is rotated in a clockwise direction. Position "0" enables continuously on. Position "1" corresponds to a minimum delay time of one pulse per second, and position "F" indicates the maximum delay of 15 seconds between pulses. The fine adjustment potentiometer next to this control is for calibrating the one-second interval (fully counterclockwise - decrease, fully clockwise - increase)

PULSE DURATION ADJUSTMENT

The duration (on time) of each pulse is adjustable over a range of 50-750 milliseconds (ms). This adjustment is made by summing the calibrated interval values of the dual in-line package (DIP) switches 1-4 on the 5-position DIP switch located in the upper right corner of the auxiliary board. Each switch has an assigned "On Time" value, and the on time for each pulse is determined by the sum of the values of switches in the "off" position. The "On Time" values for each switch are as follows:

SW-1 = 50 ms
SW-2 = 100 ms
SW-3 = 200 ms
SW-4 = 400 ms

For Example: If SW-1, and SW-4 are in the "off" position, the solenoid on time for each pulse would be 450 milliseconds. (50 + 400 ms = 450 ms).

The DOWN position is "on" for these switches. The fine adjustment next to this control adds an extra 50 ms to the total pulse time (fully counterclockwise - adds 50 ms, fully clockwise - adds no time).

POWER ON/OFF

Switch 5 on this DIP switch is the on/off power switch for the auxiliary board, and must be set to the "on" position for any functions to be active. The UP position is "on" for this switch, the opposite of the other dip switches.

PULSE INDICATOR

The Pulse Indicator flashes when the system is pulsing.

OVERLAP JUMPER

With the Overlap Jumper installed, and solenoid valves plugged into output ports 2 & 4, both valves are energized when the sequencing circuit advances to position #3 (LEDs for positions #2,3,4 are all on at this time). This allows for programming a sampling period when both bags are filling simultaneously.

This page was intentionally left blank.

4 PARTICULATE MATTER SAMPLING

Sampling procedures for TSP, PM₁₀, and PM_{2.5} are identical except for the configuration of the preseparator/filter holder assembly.

Consumables

During particulate matter sampling, the following consumables are needed for proper operation of the MiniVol:

- Impactor grease - Glisseal® Ht, Apiezon® M Grease, etc.
- Solvent to mix with grease - hexane, white gas, lantern gas, etc.
- 47 mm filters - pure quartz, pure Teflon®, Teflon®-coated glass, etc.
- Petri slides - for storage and transport of the filters.

A microbalance accurate to one microgram is needed to weigh the filters.

Airmetrics offers all of the above consumables (except the solvent), along with filter weighing services.

Siting Requirements

Siting recommendations in this manual conform to the U. S. Environmental Protection Agency requirements as stated in the U. S. Code of Federal Regulations (40 CFR part 58, Appendix E). When operating the sampler in locations under another jurisdiction, the operator should follow the appropriate guidelines.

The MiniVol should be positioned with the intake upward and should be located in an unobstructed area at least 30 cm from any obstacle to air flow. Accessibility to the unit under all weather conditions, along with safety and security of the monitoring personnel and equipment, should be prime considerations.

Attaching the Mounting Cradle

The MiniVol Mounting Cradle is designed to mount onto a standard 1 1/4 inch antenna mast or comparable metal tubing (not supplied with the sampler). The mast should be strapped securely to some other suitable structure—utility pole, parking meter, fence post, *etc.* (See Figure 4.1). Available separately from Airmetrics is a Y-Bracket Assembly which attaches to poles and provides a mast for the mounting cradle. (Also shown in Figure 4.1).

Preparing the Sampler

If the sampler is equipped with a valve driver board for integrated gas sampling, make sure to turn off the power (SW-5) on the auxiliary board before sampling unless integrated gas samples will be collected simultaneously with the particulate matter samples (refer to Section 5, “Integrated Gas Sampling”, for proper sampler preparation for gas sampling). Be sure that the tubing conforms to the arrangement shown in Figure 4.2 (if a valve driver board is not attached) or Figure 5.1 (if a valve driver board is attached).

TSP - Remove the impactor from the preseparator/filter holder assembly prior to sampling. Since the impactor will not be used, greasing and cleaning of the impactor’s target disk need not be done.

PM₁₀ - Use a PM₁₀ impactor in the preseparator/filter holder assembly (see Figure 4.3). Greasing and cleaning of the impactor's target disk should be performed initially and after every seventh sample (or more often if heavy loading is observed). Refer to Section 7, Maintenance, "Impactor Cleaning."

PM_{2.5} - Use a PM_{2.5} impactor in the preseparator/filter holder assembly and a PM₁₀ impactor in a multiple impactor adapter mounted on the preseparator assembly tube but below the rain hat (see Figure 4.4). Greasing and cleaning of the impactors' target disks should be performed initially and after every seventh sample (or more often if heavy loading is observed). Refer to Section 7, Maintenance, "Impactor Cleaning."

To remove impactors, use your thumb to simply push the impactor out of its tube from bottom to top. When correctly installed, the impactor's top is flush with the surrounding preseparator tube or multiple impactor adapter tube.

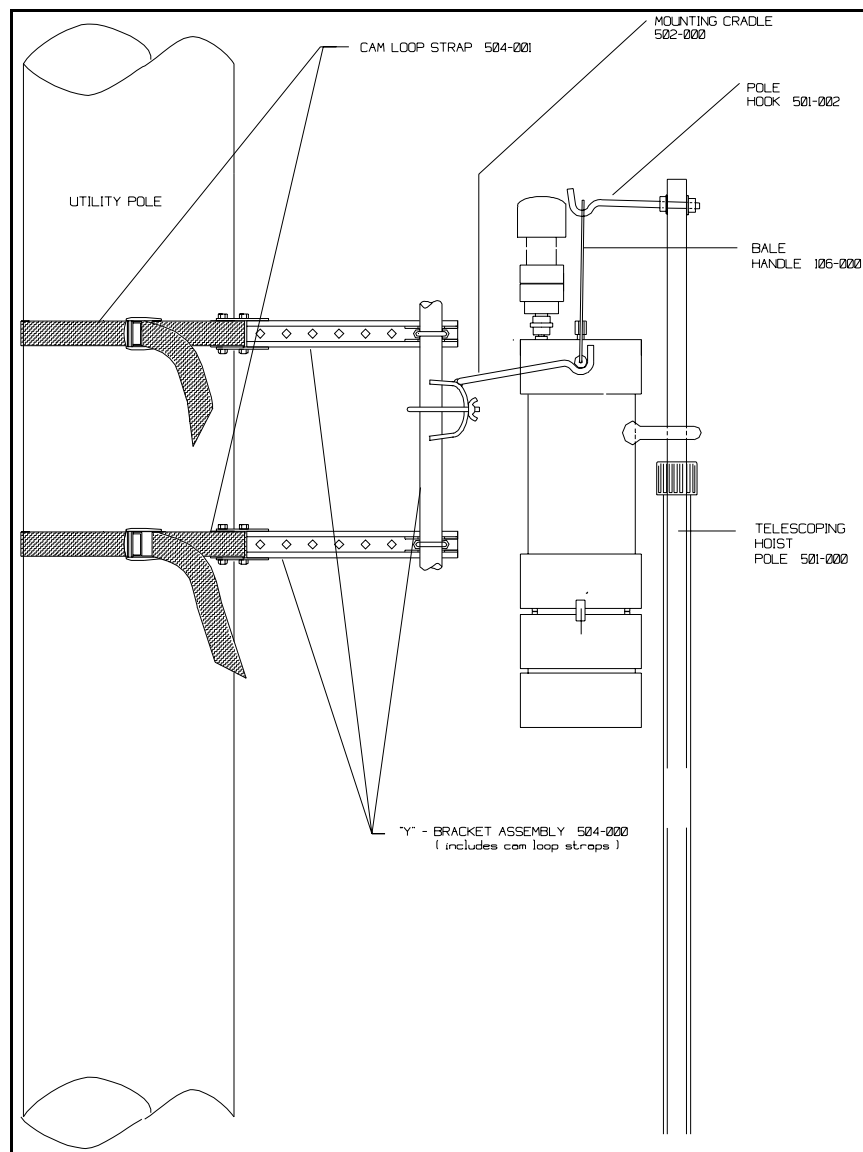

Figure 4.1. Mounted Sampler

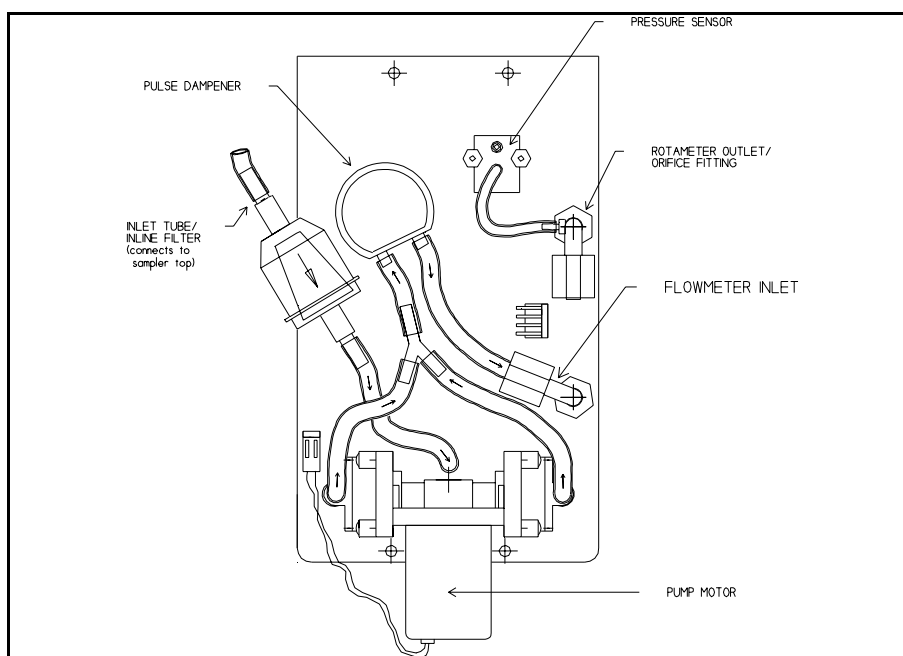

Figure 4.2. Tubing Configuration for PM Sampling Mode

Before transporting the MiniVol to the field, perform a laboratory check to determine if it is operational. Turn the sampler on and observe the motor performance. Check all tubing for crimps, cracks or breaks. Conduct a flow check with a "dummy" filter in place to simulate the load against the sampler pump. Investigate and correct any malfunctions before proceeding. Perform a single-point flow rate check using a soap-bubble meter or other flow measuring device of known accuracy and compare to the curve established during calibration. The flow should be within $\pm 15\%$ of 5 lpm at current conditions. If the unit fails to operate in this range, check the sampler for obvious crimps, battery malfunction, etc. The sampler must be repaired or recalibrated if the flow criteria are not met.

FLOW RATE

The particle size cut point of the preseparator is a function of the velocity with which the air stream passing through the preseparator hits the target. The preseparator is designed to have the correct cut point at an air flow rate of 5 lpm at ambient conditions. Since the density of air and the behavior of the flowmeter are functions of the ambient air temperature and atmospheric pressure, a flow rate set point must be calculated for each different sampling project.

The sampler air flow calibration curves that are supplied with each sampler contains the necessary information needed to determine the flowmeter set point for a particular ambient condition. Appendix A contains the complete instructions in calculating the flow set points.

FLOWMETER CALIBRATION

The sampler should be recalibrated if the flowmeter or the pulse dampener is replaced.

Preseparator/Filter Holder Assembly

Depending on the required particle size separation, the configuration of the Preseparator changes. The attached Filter Holder Assembly contains a filter cassette in which the 47mm filter is supported by a filter support screen (see Figure 4.3 for PM₁₀ and Figure 4.4 for PM_{2.5}).

CLEAN AND GREASE IMPACTOR

Initially, and after every seventh sample, the impactor target should be cleaned and greased under a laboratory fume hood (preferably) or any well ventilated area (including on-site). The cleaning frequency should be increased or decreased depending on the ambient loadings and degree of soiling observed on the target disk.

For Impactor cleaning procedures, see Section 7, Maintenance, "Impactor Cleaning."

INSTALLING FILTERS

This procedure should take place in a laboratory or other clean area. Contact with and handling of all filters should be limited to the edges of the filters. Also, the use of non-serrated, Teflon®-tipped forceps is strongly recommended. Filters should be kept in protective petri slides. Filters must never be bent or folded.

1. Select a filter and remove cover from petri slide.
2. Using forceps, install the new filter into the filter cassette.
3. Place the filter cassette in the filter holder.
4. Replace preseparator adapter and screw down snugly.
5. Place an identifying tag on the filter holder so that the ID number of the filter mounted in the holder is known.
6. Place a clean, plastic bag over the top of the preseparator adapter inlet and push the rain cap snugly into place over the bag.
7. Place the entire clean filter assembly into a second plastic bag, or other case, for transporting to the site. It is best to keep the filter assembly in a vertical position until installed on the sampler.

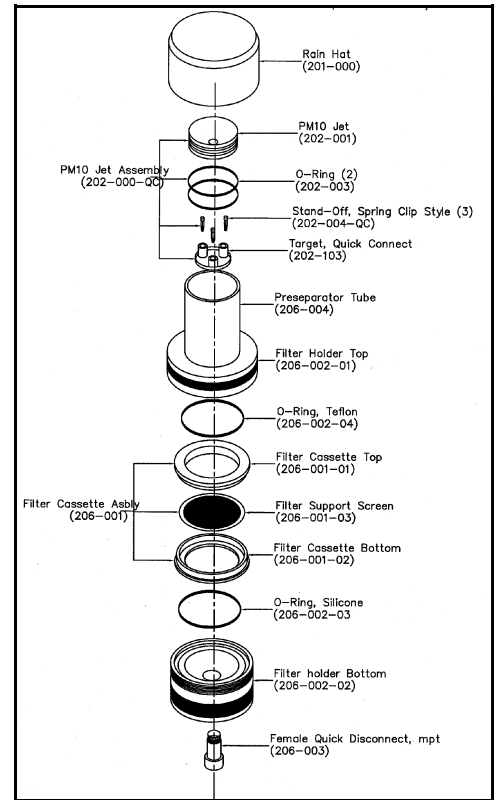

Figure 4.3. PM₁₀ Preseparator and Filter Holder Assembly

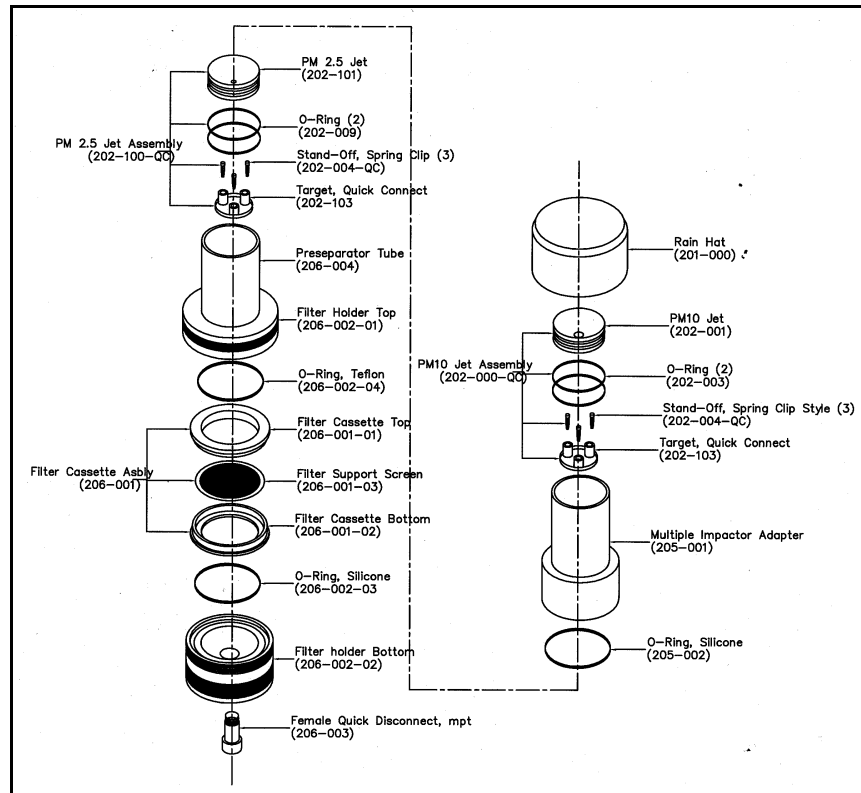

Figure 4.4. PM_{2.5} Preseparator and Filter Holder Assembly

Preparing the Battery Pack

BATTERY CHARGING

After each sampling run, the used battery pack should be charged for a minimum of 18 hours or overnight. The battery need not be completely discharged before recharging.

- The new Universal Transformer **can** charge both types of batteries. The old batteries, however, will take slightly longer to charge on the Universal Transformer (18 hours vs. about 14 hours).



DO NOT store the battery while attached to the sampler as this will cause irreparable damage to the battery. The indicator lights that remain on when the battery is connected to the sampler will discharge the battery past its 10.3 volt safety cut-off point.

See “Charging Batteries” in the Getting Started section for instructions in the proper procedure to follow in recharging the batteries.

CHANGING/INSTALLING BATTERY PACK ON SAMPLER

1. Place the charged battery pack beside the sampler.
2. Unclasp the two side latches at the base of the sampler.
3. Lift the sampler off the used battery pack and place the sampler on the charged battery pack.

Note: The pin on the sampler closest to a side clip inserts into the odd colored receptacle on the battery pack (see Figure 2.1).

4. Reclamp the two side latches.

OTHER BATTERY CHECKS

A single AA battery on the circuit board operates the Programmable Timer. The lifetime for this battery is approximately six months when it is left in place on the circuit board. Be sure to observe the correct polarity when inserting a new AA battery into the battery compartment.

Refer to Section 8, "Troubleshooting" for additional comments on battery functions.

Setting the Desired Sampling Time

Determine the time of the day when the sampler is to turn on and off. Program the timer to turn the sampler on and off at these times (see "Programming the Timer" in Section 2).

Particulate Matter Sampling Procedure

After the sampler has been assembled, adjusted, verified to be in proper working order, and a filter loaded in the Filter Assembly, the sampler is ready to collect air samples. **Note:** For a quick reference to the following steps, see "Particulate Matter Sampling Routine at Site" (Appendix C). If a gas sample is also to be collected simultaneously, refer to Section 5, "Integrated Gas Sampling" for proper gas sampling procedures.

1. Carefully transport the sampler to the field site. Verify that the sampler, when finally installed in the mounting cradle, will be positioned with the intake upward in an unobstructed area at least 30 cm from any obstacle to air flow.
2. Place the sampler on a firm level surface.
3. Remove the clean Preseparator/Filter Holder Assembly from the plastic transport bag and remove the protective plastic bag under the rain cap. Attach the assembly to the sampler top at the quick connect.
4. Record the following information on the PM Field Data Sheet: number of the filter, the battery ID, sampler ID, ambient temperature and pressure, flowmeter reading, and elapsed time meter reading. (see Figure G.1 insert at the end of this Manual).
5. Unscrew either cap of the bale assembly bar and remove the bale assembly.
6. Lift the pump and timer assembly out by the 6" diameter top cap and rest it on the edge of the sampler casing, using the triangular mount stand. Take care not to pull the connecting wire loose or jar the pump hose fittings. Hold the top cap and do NOT grasp the center of the circuit board.
7. To obtain the beginning flow rate, press the ON/AUTO/OFF button to start the pump. On the LCD display, the horizontal bar should move to "ON".
8. If the flowmeter, which should be in the vertical position, indicates zero or a very low reading, check for restrictions in the tubing, or improperly seated screw fittings between the pump and the flowmeter.
9. Using the Flow Rate Adjustment control (see Figure 3.1), set the flowmeter flow within specifications for the project temperature and pressure conditions. Take the reading of the flowmeter from the center of the ball. (See Appendix A).

10. Press the ON/AUTO/OFF button twice to stop pump.
11. Press the ON/AUTO/OFF button to set the timer to "Auto" mode. The Sampler MUST be in "Auto" mode before the operator leaves.
12. Place the pump and timer assembly back into the sampler body. Replace the bale assembly bar.
13. Using the hoisting pole, hook the bale assembly bar and raise the sampler, as vertically as possible, to the mounting cradle. This position not only more easily accommodates the sampler's weight, but prevents the hook from hitting and possibly dislodging or breaking the preseparator/filter holder assembly. (See Figure 4.1).

Particulate Matter Sample Retrieval

As soon as possible after the end of the sampling period, the operator should return to the monitoring site to retrieve the exposed filter. Potential for filter damage or changes in sample mass due to particle loss, passive deposition, or volatilization increases if the filter is left in the sampler for extended periods. On the Field Data Sheet record the ambient temperature (T_a), barometric pressure (P_a), and flowmeter reading.

Note: T_a and P_a readings may be estimated on site or may be obtained from a nearby US National Weather Service Forecast Office or airport weather station. Barometric pressure readings obtained from airports must be at station pressure (not corrected to sea level), and they may have to be corrected for differences between the elevation of the monitoring site and that of the airport. If T_a and P_a readings are not available, seasonal average temperature (T_{avg}) and barometric pressure (P_{avg}) may be substituted. Care must be taken that the actual conditions at the site can be reasonably represented by such averages. It is therefore recommended that seasonal values represent actual values within 20 °C and 40 mm Hg.

Note: If a gas sample is also being retrieved, refer to Section 5 "Integrated Gas Sampling" for proper gas sample retrieval.

1. Remove the sampler from the mounting cradle using the hoisting pole. Position yourself directly under the sampler, hook the bale assembly bar, and lower the sampler as vertically as possible. This vertical take-away not only accommodates the sampler's weight, but prevents the hook from dislodging the rain cap or damaging the preseparator/filter holder assembly (see Figure 4.1).
2. Place the sampler on a firm level surface.
3. Unscrew either cap of the bale assembly bar and remove the bar. Newer samplers come with quick-release snap buttons, so the bar need not be removed.
4. Lift the pump and timer assembly out by the top cap and rest it on the edge of sampler body using the triangular mount stand. Take care not to pull the connecting wire loose and hold the top cap.
5. Check the sampler face plate for any error conditions. If an error conditions exists, refer to the "Error Conditions" section at the end of this chapter.
6. Verify correct time and day of week on time LCD.
7. Record elapsed time as shown on the Elapsed Time Totalizer.
8. Obtain ending flow rate:
 - Press the ON/AUTO/OFF button twice to start the pump.

- With the flowmeter in a vertical position, record flow rate to the nearest 10th of liter/minute (read at center of ball).

Note: If flowmeter indicates zero or very low reading, check the quick-disconnect to be sure the filter assembly is completely connected.
 - Press the ON/AUTO/OFF button twice to stop the pump.
9. Place the pump and timer assembly into the sampler body. Do not replace the bale assembly bar.
 10. Exchange a new preseparator/filter holder assembly for the exposed filter holder assembly. If possible, perform the exchange inside a building or vehicle to minimize exposure to the elements. Perform a cross-check of the exposed filter number with the filter number recorded on the Field Data Sheet for the run just completed. Also, check the filter number against the site number.
 11. Change Battery Pack (see page 17)
 12. Obtain beginning flow rate (see "Particulate Matter Sampling Procedure" above, steps 7 to 12).
 13. Make sure the timer is set for the desired period and in the "AUTO" mode.
 14. Place the pump and timer assembly back into sampler body. Replace the bale assembly bar.
 15. Using the hoisting pole, hook the bale bar and raise the sampler, as vertically as possible, to the mounting cradle.

EXPOSED FILTER

1. In the laboratory, unscrew the filter holder and remove the filter cassette.
2. Locate the petri slide with the filter number which matches the number on the side of the filter holder assembly. This is the original petri slide in which the filter came.
3. Use the cassette separator (P/N 600-007) to remove the top half of the filter cassette.
4. Using tweezers, carefully remove the exposed filter from the filter cassette and place it into its original petri slide, replacing the petri slide lid when finished. (Be sure to replace the filter support screen in the filter cassette assembly).
5. Remove the old ID tag from the filter holder assembly base and discard. (Recheck this number to be sure it matches the number on the petri slide.)

ERROR CONDITIONS

Low Battery Indicator ON

Should the Low Battery Indicator be ON at the end of a sampling period, check the Elapsed Time Totalizer to determine the length of time the sampler ran before shutting off. If the time is short (e.g., only 2 hours out of a programmed 8 or 10 hours), perhaps the battery was not completely charged or is failing to hold a charge. Note the battery number and, after recharging in the lab, observe performance in the next sampling period. If the battery fails again, it is most likely defective and should be replaced.

If a different battery performs in the same manner after shown to be fully charged, the pump motor is perhaps drawing more current than it should. If possible, install a pump from another sampler. If this solves the problem, the previous pump motor is likely defective and should be replaced. If the problem continues, a more serious fault is occurring which should be referred to Airmetrics (see Appendix D).

Low Flow Indicator ON

Should the Low Flow Indicator be found ON at the end of sampling period, first check the Elapsed Time Totalizer to determine the length of time the sampler ran before shutting off. The possible causes for low flow are:

- **Low Battery:** Although power did not fall to the 10.3V lower limit that would shut down the system, the pump may not have been receiving enough voltage to maintain the desired air flow.
- **Air Restriction:** If the battery is sound, the problem may be due to a restriction in the air inlet, filter holder, or tubing. Check for crimps or other possible restrictions. Also, a broken or loose tubing fitting on the outlet side of the pump could cause a low flow condition. It is also possible for excessive moisture on the filter (rain, condensation) to cause enough flow resistance for the Low Flow Indicator to come on.
- **Pump Malfunction:** The low flow condition could be the result of decreased pump efficiency, which is usually caused by damaged or contaminated pump head components (valves, diaphragms). Check to see if the pump can maintain a free (unrestricted) airflow rate of at least 5 lpm. If not, see Section 7 for pump maintenance instructions.
- **NOTE:** The Low Flow Threshold Indicator normally lights whenever the sampler is attached to a power source but is not operating.

Overriding Low Flow/Low Battery Indicators

When Low Flow and Low Battery Indicator lights are on, the system can be restarted by pressing the Reset Switch. The system will usually run enough to perform a brief field inspection and to obtain final flow rates. Pressing and holding the switch provides continuous override of the fault circuit.

This page was intentionally left blank.

5 INTEGRATED GAS SAMPLING

MiniVol sampling procedures for all non-reactive gases are the same. It should also be noted that the MiniVol simply collects a gas sample. Analyzing a gas sample must be done separately with the proper gas analyzing equipment.

Consumables

No consumables are needed except for the occasional replacement Tedlar® bag should one become damaged. Contact Airmetrics for replacement bags.

Siting Requirements

Siting recommendations in this manual conform to the U. S. Environmental Protection Agency requirements as stated in the U. S. Code of Federal Regulations (40 CFR part 58, Appendix E). When operating the sampler in locations under another jurisdiction, the operator should follow the appropriate guidelines.

As with particulate matter sampling, the MiniVol should be positioned with the intake upward and located in an unobstructed area at least 30 cm from any obstacle to air flow. Accessibility to the unit under all weather conditions, along with safety and security of the monitoring personnel and equipment, should be prime considerations.

Attaching the Mounting Cradle

Mount the MiniVol cradle onto a standard 1 1/4 inch antenna mast or comparable metal tubing, which itself is strapped securely to another supporting structure—utility pole, parking meter, fence post, *etc.* (see Figure 4.1).

Available separately from Airmetrics is a Y-Bracket Assembly for pole mounting which provides a mast for attachment of the mounting cradle.

Preparing the Sampler

To collect integrated gas samples, the sampler must be fitted with the optional valve driver board. If your original order specified integrated gas sampling attachments, the sampler arrived prefitted for gas sampling. To prepare for the gas sampling, you need only change the bale bar, attach the bag canisters, and turn on the Valve Driver Board. However, if you wish to retrofit the sampler for integrated sampling, you must make several minor modifications to the sampler body and control board. (Contact Airmetrics for parts and information on this procedure). The gas sampling tubing configuration is illustrated in Figure 5.1.

OPERATION MODES - STANDARD MODE OR OVERLAP MODE

In **Standard Mode** the sampler can be set to take samples at different times during which either one or two bags can be filled. In this mode, only one bag can be filled during a given period.

To operate in Standard Mode:

- Plug the solenoids into desired positions 1-4.
- Remove Overlap Jumper.

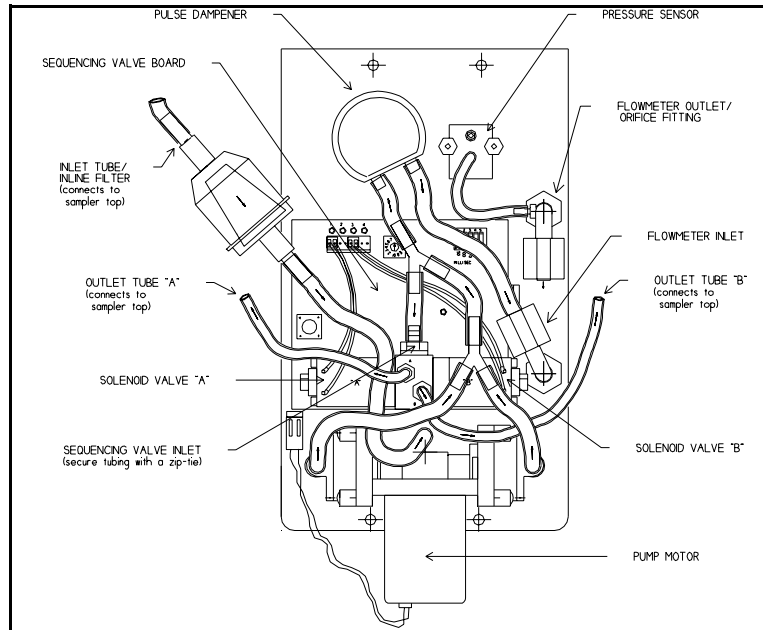

Figure 5.1. Tubing Configuration for Integrated Gas Sampling Mode

- Advance to desired starting channel with Manual Advance Button.

Note: The Manual Advance only functions when the pump is off. Each time the pump is turned off, the channel advances automatically.

- Set timer as desired.

Active Solenoid Output Indicators in standard mode:

- ⊗○○○ channel 1 on
- ⊗○ channel 2 on
- ⊗ channel 3 on
- ⊗ channel 4 on

Example 1: We wish to take two CO samples, one bag filling from 7:00 am to 3:00 pm, and the second from 3:00 pm to 11:00 pm.

- 1) Plug bag 1 solenoid into Solenoid Output Connector 1; plug bag 2 solenoid into Solenoid Output Connector 2.

2) Set the timer: set timer Program 1 to turn on at 7:00 am and off at 3:00 pm. Set timer Program 2 to turn on at 3:01 pm and off at 11:00 pm. The one minute delay between the first program's off time and the second program's on time is necessary to advance the sequencing valve to the next cycle.

Example 2: We wish to take two CO samples (from 7:00 am to 3:00 pm, and from 3:00 pm to 11:00 pm) while also collecting a PM₁₀ sample from 1:00 am to 11:00 pm.

1) Plug bag 1 solenoid into Solenoid Output Connector 2; plug bag 2 solenoid into Solenoid Output Connector 3.

2) Set the timer:

a) Set timer Program 1 to turn on at 1:00 am and off at 7:00 am. During this program, neither bags will be filled but air will be drawn through the PM₁₀ filter.

b) Set timer Program 2 to turn on at 7:01 am and off at 3:00 pm. Air will be drawn through the filter and bag 1 will be filled.

c) Set timer Program 3 to turn on at 3:01 pm and off at 11:00 pm. Air will be drawn through the filter and bag 2 will be filled during this programmed step.

In **Overlap Mode** the sampler can be set to overlap the sampling periods for the bags. For example; the operator could set the sampler to collect air in one bag from 10:00 am to 6:00 pm and in the other bag from 3:00 pm to 11:00 pm. During the overlapping period from 3:00 pm to 6:00 pm the sample would be collecting air in both bags simultaneously.

To operate in Overlap Mode:

- Plug solenoids into positions 2 & 4.
- Place the Overlap Jumper on the pins.
- Advance to channel 2 with Manual Advance Button.

Note: The Manual Advance only functions when the pump is off. Each time the pump is turned off, the channel advances automatically.

- Set timer as desired.

Active Solenoid Output Indicators in Overlap Mode:

- ⊛○○○ channel 1 on (this setting does nothing)
- ⊛○○ channel 2 on
- ⊛⊛⊛ channels 2 & 4 on
- ⊛ channel 4 on

Example: We wish collect air in one bag from 10:00 am to 6:00 pm and in the other bag from 3:00 pm to 11:00 pm.

1) Place the Overlap Jumper on the pins.

2) Plug bag 1 solenoid into Solenoid Output Connector 2; plug bag 2 solenoid into Solenoid Output Connector 4.

3) Set the timer:

- a) Set timer Program 1 to turn on at 10:00 am and off at 3:00 pm. During this program, bag 1 will be filling.
- b) Set timer Program 2 to turn on at 3:01 am and off at 6:00 pm. During this program, both solenoids will be active and both bags will be filling simultaneously.
- c) Set timer Program 3 to turn on at 6:01 pm and off at 11:00 pm. During this programmed step, only bag 2 will be filling.

ADJUSTING PULSE FREQUENCY AND DURATION

The rate at which the bags are filled is set by using a tunable intervalometer or pulse circuit which can be adjusted both for frequency (continuously on to 1 pulse in 15 seconds) and for duration (50 ms to 750 ms). The pulse frequency is controlled by the **Intervalometer Frequency Adjustment**, while the duration of each pulse is set by the **Pulse Duration Adjustment**. The **Power on/off** (sw-5) enables gas sampling mode.

Adjusting the pulse circuit using the Intervalometer Frequency Adjustment and the Pulse Duration Adjustment is accomplished through trial and error. A test period in the laboratory is therefore required before the sampler can be moved to the field site. The object is to achieve a combined pulse duration and interval that will integrate a sample of air over the programmed period of time. At the end of the programmed period the bags should be 80-90% filled. That is, the bag should not be tightly filled, since there would be no way of knowing at what point the bag became filled.

The pulse duration and frequency controls can be adjusted to suit the requirements of the task at hand. For example; one can take many small samples or a few large samples over the same period of time depending on the needs of the operator.

Pulse Interval Adjustment

The pulse interval (off time) of the circuit is adjustable over a range of 0-15 seconds by a 16-position rotary switch. This switch is located just to the right of the solenoid valve output connectors. Switch positions are marked clockwise 0-9, and continue A-F. The interval between pulses increases in 1-second increments as the switch is rotated in a clockwise direction. Position "0" enables continuous pulsing. Position "1" corresponds to a minimum delay time of one pulse per second, and position "F" indicates the maximum delay of 15 seconds between pulses. The fine adjustment potentiometer next to this control is for calibrating the one-second interval (fully counterclockwise - decrease, fully clockwise - increase).

Pulse Duration Adjustment

The duration (on time) of each pulse is adjustable over a range of 50-750 milliseconds. This adjustment is made by summing the calibrated interval values of DIP switches 1-4 on the 5-position DIP switch located in the upper right corner of the auxiliary board. Each switch has an assigned "On Time" value, and the on time for each pulse is determined by the sum of the values of switches in the "off" position. The "On Time" values for each switch are as follows:

SW-1 = 50 ms
SW-2 = 100 ms
SW-3 = 200 ms
SW-4 = 400 ms

For Example: If SW-1, and SW-4 are in the "off" position, the solenoid on time for each pulse would be 450 milliseconds. (50 + 400 ms = 450 ms).

The DOWN position is "on" for these switches. The fine adjustment next to this control adds an extra 50 ms to the total pulse time (fully counterclockwise - adds 50 ms, fully clockwise - adds no time).

Calculate an approximate pulse duration and frequency that would fill the 6 liter Tedlar® bag over the desired collection period.

Example: Suppose you wish to fill a 6 liter bag over a period of 4 hours. The first step would be to determine the amount of air pumped during a single pulse. This can be done by replacing the bag at the mini quick-connect with a bubble flow meter, and starting the pump in the gas sampling mode. If 1 cc of air was pumped during a single pulse, a 10 second interval between pulses would result in 6 cc being pumped per minute, or 360 cc per hour, or 1440 cc over four hours. Since this amount falls considerably short of 6 liters, the pulse duration and/or frequency would have to be increased accordingly.

In this manner, calculate an approximate pulse duration and pulse frequency for the test period.

NOTE: New samplers are factory calibrated to deliver 1 cc per pulse.

Preparing the Sampler

1. Attach a new battery pack.

Important Note: The Valve Sequencing Board automatically resets when the sampler's main power is interrupted. Consequently, the battery must be changed *before* setting the sequencing circuit.

2. Unscrew either cap of the bale assembly bar and remove the bale assembly.
3. Disconnect canister tubing and remove the canisters.
4. Lift the pump and timer assembly out by the 6" diameter top cap and support the mounting board on the edge of the sampler casing using the pump mount stand and taking care not to pull the connecting wire loose. Hold the top cap and do not grasp the center of the circuit board. Leave the battery attached.
5. Set the calculated pulse duration for the test period with the Pulse Duration Control.
6. Set the interval between pulses to the calculated setting by turning the Intervalometer Frequency Adjustment. The control is marked 0-9 then A-F where zero is continuous pulsing and F is one pulse every 15 seconds.
7. Turn on the valve sequencer board by moving the Power ON/OFF Switch to the UP position. Note that the other four dip switches (which control the pulse duration) are activated in the down position.
8. Set the Valve Driver Board to either standard or overlap mode using the Overlap Jumper.
9. Program the timer for the desired test period.
10. Set the timer to "Auto" to begin the test period.
11. Replace the pump and timer assembly into sampler body. Replace the 6" cap, the bale assembly bar, and the canisters. Reattach the canister tubing.
12. At the end of the test period, increase or decrease the pulse frequency or pulse duration depending on the fullness of the bags.
13. When test results are within adequate limits, attach new battery pack and move sampler to field site.

INSTALLING TEDLAR® BAGS AND ATTACHING CANISTERS

Four Tedlar® bags, protective canisters, and tubing are provided for gas sampling. The bags attach to the canister top caps with bulkhead fittings, to which tubing is connected on the outside that runs to the mini quick-connects on the sampler body (see Figure 5.2). Before attaching the canister to the sampler, the bags should be completely evacuated.

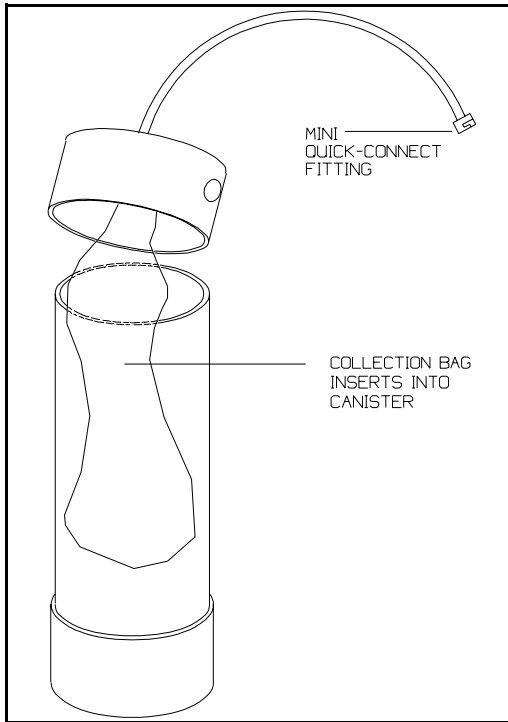

Figure 5.2. Installing Tedlar® Bag

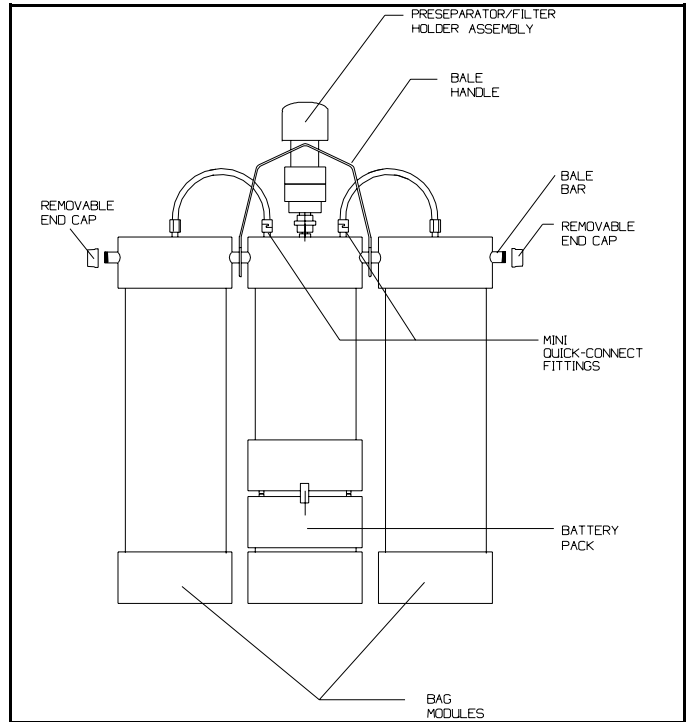

Figure 5.3. Attaching Bag Canisters and Tubing

1. Evacuate bags using either a small vacuum pump or the sampler pump. Connect the bag tubing to an inlet side of the sampler pump, and run the pump in particulate matter sampling mode until bag is flat and empty.
2. Remove the short bale assembly bar and insert the longer canister bale assembly bar.
3. Slide canisters holding empty bags onto the bar and attach end caps.
4. Snap on bale handle.
5. Attach tubing from canisters to the mini quick-connect fittings on the sampler's 6" top cap (see Figure 5.3).

Integrated Gas Sampling Procedure

After the sampler has been assembled, the pulse frequency and duration correctly established through a test run, and a fresh battery installed, the sampler is ready to collect air samples at a field site. (See Figure G.2 insert at the end of this Manual for a sample Integrated Gas Field Data Sheet.)

NOTE: If a particulate sample is being collected simultaneously, refer to Section 4, "Particulate Matter Sampling" for proper particulate sampling procedure.

1. Transport the sampler to the field site. Verify that the sampler when installed in the cradle will be positioned with the intake upward in an unobstructed area at least 30 cm from any obstacle to air flow.
2. With the sampler on a firm level surface, unscrew either cap of bale assembly bar and remove bale assembly.
3. Detach canister tubing at mini quick-connect fittings and remove canisters.
4. Lift pump and timer assembly out by the 6" diameter top cap and support the mounting board on the edge of the sampler casing, taking care not to pull the connecting wire loose or jar the pump hose fittings. Hold the control assembly by the top cap and do NOT grasp the circuit board.
5. Check that the Valve Driver Board is operational (Power Switch is in UP position, Active Solenoid Output Indicators on).
6. Verify that all hose connections are secure. Check the pump by turning it on and then off.
7. Select the desired mode of operation (standard or overlap) with the Overlap Jumper. Make sure that the solenoid valves are plugged into the correct output connectors.
8. Use the Manual Sequence Advance Button to select the required channel.

Important Note: The Valve Sequencing Board automatically resets when the sampler's main power is interrupted. This is why the battery must be changed *before* setting the sequencing circuit.

9. Program the on/off cycles for the desired sampling period (see page 5).
10. Press the ON/AUTO/OFF button once to set the timer to "Auto" mode. The sampler must be in Auto mode before the operator leaves.
11. Place pump and timer assembly into sampler body. Replace bale assembly bar and canisters, and connect tubing.
12. Using the hoisting pole, hook the bale and raise the sampler as vertically as possible to the mounted mounting cradle (see Figure 4.4).

Gas Sample Retrieval

As soon as possible after the end of the sampling period, the operator should return to the monitoring site to retrieve the filled bags. If a particulate sample is being collected simultaneously, refer to Section 4, "Particulate Matter Sampling" for proper particulate sample retrieval procedures.

Note: For a quick reference to the following steps, see Appendix C, "Integrated Gas Sampling Routine at Site."

1. Lower sampler from cradle using the hoisting pole. Positioned directly under the sampler, hook bale and lower away as vertically as possible. This vertical take-away is critical since the hook may dislodge or damage the rain cap or sampler head. Also, the weight is more easily managed if the sampler is lowered vertically (see Figure 4.4).
2. With the sampler on a firm level surface, unscrew either cap of the bale assembly bar and remove bar assembly. Detach canister tubing at the mini quick-connect fittings and remove canisters.
3. Lift pump and timer assembly out by the top cap and rest on the edge of the sampler body, taking care not to pull the connecting wire loose. Hold the top cap. Do NOT grasp the circuit board.
4. Verify correct time and day of week on time LCD.
5. Record elapsed time as shown on the elapsed time accumulator, which should match the programmed time set at the beginning of the sampling period.
6. Check and record the fullness of the bag(s), adjusting the pulse interval or duration if necessary.
7. Program timer for new sampling period (see page 5).
8. Set to "Auto" mode.
9. Change battery pack (see page 17).

Important Note: The Valve Sequencing Board automatically resets when the sampler's main power is interrupted. This is why the battery must be changed *before* setting the sequencing circuit.

10. Check the Active Solenoid Output Indicators to make sure that the desired starting channel has been selected. Use the Manual Sequence Advance Button to select the required channel if necessary.
11. Lower pump and timer assembly into sampler body.
12. Replace bale bar assembly, attach new canisters, and connect tubing.
13. Using the hoisting pole, hook the bale and raise the sampler to the mounting cradle as vertically as possible.

6 HARDWARE DESCRIPTION

Pneumatic System

PNEUMATIC SYSTEM FLOW SCHEMATIC

See Figure 6.1.

FILTER HOLDER ASSEMBLY

A 47 mm diameter filter cassette and filter holder assembly is used to hold the filter media.

FLOWMETER

A standard variable Flowmeter with a range of 1 to 10 lpm is used to indicate sampling flow rate. The uncalibrated accuracy of the flowmeter is $\pm 4\%$ of full scale.

FLOW CONTROL SYSTEM

A monitoring system designed by Airmetrics electronically controls pump speed to maintain a specified flow setting by measuring the drop in air pressure at the outlet of the flowmeter. The Flow Control System is temperature compensated for reasonable changes in ambient temperature and pressure.

MINIATURE BRUSHLESS D.C. DOUBLE ACTING DIAPHRAGM PUMP

The Double Acting Diaphragm Pump is powered by a Brailsford Type "T" magnetically commutated motor. The two pumping sections may be used independently, connected in parallel for increased flow or in series for higher pressure capacity. The unit is designed for 10 volt operation, but may be operated from any voltage between 5 and 14 volts. Running speed varies between 2500 and 3600 RPM depending upon the voltage and back pressure. Motor and crank pin bearings are double shielded, instrument type ball bearings lubricated for the life of the unit. The pumping sections consist of synthetic rubber diaphragms housed in molded plastic casing directly driven from the motor shaft by a scotch yoke-crank assembly. Valves are of the self-biasing fiberglass reinforced synthetic rubber type. No metallic springs are used in the blower. The air pumped contacts only the plastic and synthetic rubber areas. All moving parts are completely enclosed. The service life of the motor is in excess of 10,000 hours continuous duty. The diaphragm valve assemblies are easily replaceable. The service life expectancy of these assemblies are a function of the environmental conditions, including the gases being pumped, delivery rate, and back pressure. Minimum service life for the pumping sections is on the order of 5000 or more hours continuous duty.

The motor generates no radio frequency interference and all electronic components are contained within the motor housing. Overall weight is 12.1 ounces (344 grams).

Electronics System

MOTHERBOARD

Virtually all sampler components connect to the motherboard--the pump, programmable timer, elapsed time totalizer, flowmeter, and flow control components. Flow control, intervalometer, and fault circuits, are built into this board, and pins are provided on the back side to mount the solenoid board for dual bag sampling.

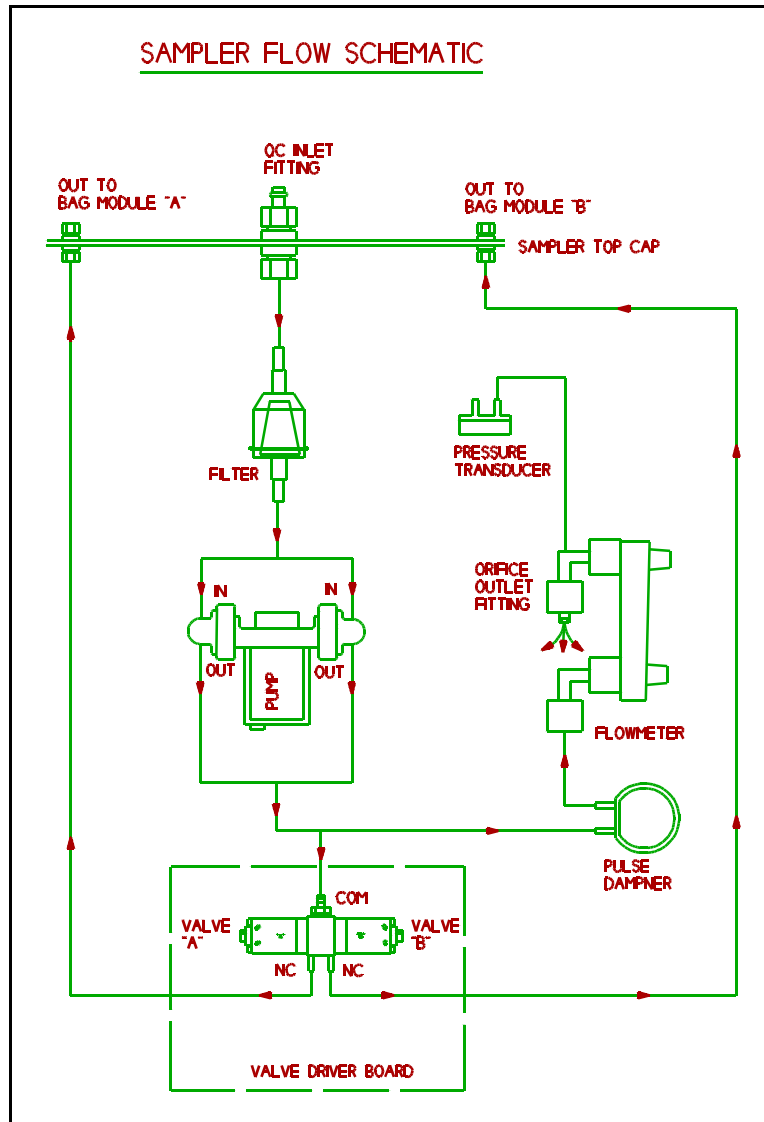

Figure 6.1. Pneumatic System Flow Schematic

POWER SUPPLY

The sampler is powered by removable battery packs which contain a 12 volt, 12 amp-hour sealed lead-acid battery and a stepped output charger circuit. The charger circuit is powered by an 18 volt AC external power supply. The charger is designed to quick-charge the battery and then switch to a "maintenance" mode to avoid an overcharge condition. The charger can be left on for an indefinite period without damaging the battery.

PROGRAMMABLE TIMER

The Programmable Timer can switch power on and off up to 6 times per day over a 7-day period and is capable of individual or multi-day timer settings. It has an easy to read liquid-crystal display and its own power supply.

FLOW CONTROLLER CIRCUIT

The Flow Controller Circuit is designed to maintain a constant pressure drop across an orifice at the output of the flowmeter. Feedback from the pressure sensor is used to control the pump speed by supplying variable voltage to the pump motor. The system is temperature compensated and is capable of maintaining a constant volumetric flow rate within $\pm 5\%$ of the set point over the range of 0 to 40°C.

ELAPSED TIME TOTALIZER

The Elapsed Time Totalizer is a non-resetable time totalizer which is activated when the programmable time controller is in the "ON" mode. The meter totals hours and tenths of hours.

INTERCONNECT BOARD

The Interconnect Board is located in the bottom of the sampler case. Power from the battery pack is routed through banana pins on the outside of the sampler bottom to the Interconnect Board. A phone plug in jack and cable is used to connect power to the motherboard. A 2 amp fuse on the interconnect board provides protection to the motherboard from short circuits and high current loads.

This page was intentionally left blank.

7 MAINTENANCE

Ideally, records reflecting the history of maintenance (including all replacement parts, supplies, costs, expenditures) should be kept for each MiniVol, along with an inventory of on-hand spare equipment.

Check sheets should be used to record preventative and/or corrective maintenance activities and the subsequent sampler calibration curve.

The sampler is comprised of four basic components: preseparator/filter holder assembly, flow control system, timer, and battery pack. Following are recommended, routine maintenance procedures for the sampler's basic components.

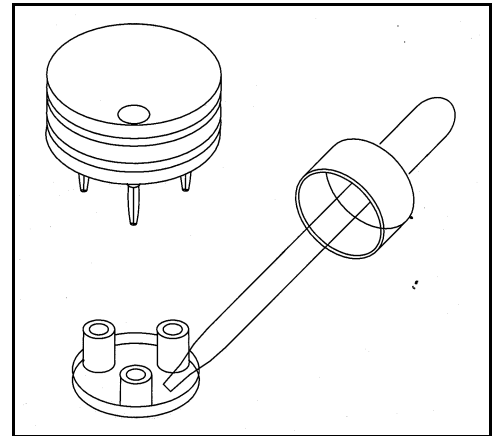

Figure 7.1. Regreasing PM_{2.5} Impactor

Preseparator/Filter Holder Assembly

IMPACTOR CLEANING

The preseparator/filter holder assembly should be dismantled and the impactor cleaned and greased at regular intervals—*i.e.*, every seventh sample to start, but if heavy loadings are observed on the target disk, as often as appropriate.

1. Unmate the preseparator sections from the filter assembly and remove the rain cap (see Figure 4.3 and 4.4).
2. Pushing with the thumb from the bottom, remove the impactor through top of the tube into the palm of your free hand.
3. Rinse the impactor from top to bottom with a solvent (hexane, white gas, lantern gas) using a squeeze bottle, paying particular attention to the impaction target disks. An acceptable alternative method of cleaning involves the use of an ultrasonic bath with mild soapy water solution.

Impaction plates on the impactor(s) should be removed prior to regreasing. The impaction plate is attached to the impactor jet by spring tension only and may be separated by simply pulling the jet from the impaction plate (see Figure 7.1).

4. Let the impactor air-dry.
5. Prepare a mixture of solvent and impactor grease in a dropper bottle until thoroughly mixed and of a fluid consistency. Use a 1-inch length of grease to 30 ml of solvent. Vigorously shake the mixture until an opaque, uniform suspension, free from grease globs, is obtained.

Other low-vapor pressure greases, such as silicone, are acceptable. However, removing the dirty grease from the impactor parts may be more difficult.

6. Put two or three drops of the cloudy solution on the target disk. The drops should saturate the disk, flowing freely to the edge.
7. Let the target disk "dry" by allowing the solvent to volatilize, leaving a thin film of grease on the target disk.

8. Inspect the O-rings on the impactor for fitness and replace if necessary. O-rings should be coated with a thin film of silicone lubricant prior to use. Remove any extraneous, loose, or hair-like shredded material from the exterior of the impactor unit since this material could fall onto the filter below and cause erroneous gravimetric results. Carefully re-insert the impactor into the top of the preseparator tube until the top of the impactor is flush with the top of the tube.

Flow Control System

Tubing, pulse dampener, and fittings must be routinely checked for crimps, cracks, or obstructions. Fittings should be inspected periodically for cross-threading and tightness. The flowmeter should be cleaned or replaced if it indicates no flow, low flow, excessive flow, or erratic flow. The flowmeter can be easily cleaned using warm water and detergent; follow the steps below:

1. Remove the inlet and outlet tubing and detach the flowmeter from the main circuit board.
2. Remove the flowmeter end caps and submerge in detergent solution. Slosh water back and forth using the ball as a self-cleaning agitator. Follow with a rinse in clean water.
3. Air dry and reinstall.

Programmable Timer

A single AA alkaline battery powers the programmable timer. It should last at least 6 months. Since the clock and timer are sealed electronic devices, any failure requires replacement of the entire unit.

Battery Pack

Remove the battery pack top using a Phillips screwdriver and look for loose connections. The battery charger board should be securely clamped to the banana jacks and the push on wire connectors securely attached to the battery. Tighten and clean any connections if corroded. The battery charging jack should be checked for a snug fit with charging transformer plug.

Cleaning/Inspecting Pump Valves and Diaphragms

After continued use, the pump valves and diaphragms will become dirty or worn. This condition usually manifests as an irregular flow rate or an inability to accurately adjust the flow rate. The pump may be unable to achieve or sustain a maximum flow rate (above 6 lpm). When these conditions occur, the pump valves must be cleaned or replaced. While the pump diaphragms are not usually affected by dirt, they will become worn and need replacement.

The side of the pump on which the valves are worn or dirty is easily determined by pinching the inlet tubes leading to the pump (first one side and then the other). Under normal conditions, the flow rate will drop by the same amount for both sides as the lines are restricted. If the flow rate drops less for one side, the valves on that side need cleaning or replacing.

When cleaning or replacing valves and diaphragms, replace or clean *all* valves and diaphragms. (A "Double Diaphragm Pump Rebuild Kit" can be obtained from Airmetrics.)

CLEANING/INSPECTING PUMP HEAD VALVES

1. Remove the pump head using a small Phillips head screwdriver. Beneath the pump head are two identical sets of three small circular rubber valve fittings (an O-ring, a white flapper valve, and a solid valve seat with a small diameter center hole). Note that the flapper valve fits *between* the O-ring and the valve seat, and that the two valve sets are inserted in reverse order to each other (*i.e.*, on one set the O-ring is on top, on the other the O-ring is on the bottom).

2. Carefully remove one set of valves using a pin or clip. Inspect each component for damage. Small cracks and imperfections can have a major impact on pump performance. Clean each valve part with a suitable silicone lubricant. *Flip* each component and replace in the same order. Repeat for the other valve set.
3. Screw on the pump head, taking care to match the alignment peg on the side of the pump head with its companion on the body of the pump.
4. Repeat for opposite side of the pump.

This page was intentionally left blank.

8 TROUBLESHOOTING

This section identifies common problems and the action necessary to correct them.

Problem	Solution
The flowmeter will not zero when a leak check is performed.	<p>Prior to every sample run with the pump running, check for leaks by removing the inlet assembly and covering the quick connect inlet with palm of the hand or a finger. The flowmeter should drop to zero. If not, a leak is present. Check all tubings and fittings for cracks and tightness. Check the pump nozzle connections and the flowmeter for cracks.</p> <p>NOTE: when checking the fittings for tightness DO NOT use a wrench or other tool to tighten these connections. These fittings are made to be finger tightened. If a leak persists after finger tightening, replace the fitting.</p>
A pump nozzle fitting has broken off.	<p>Jam a small Phillips head screwdriver or tip of penknife blade into hole of broken fitting and turn out counterclockwise. Replace with a new fitting.</p>
The charger light on top of battery fails to light when charger is plugged in.	<p>The charging LED on the top of the battery should light briefly even if the battery is already fully charged. If the LED fails to light, either the transformer is defective, the battery is defective, or the battery charger board inside the battery case needs to be replaced.</p> <p>1) Switch the transformer to the second battery pack. If the LED on this pack fails to light, the transformer is probably defective. If you have a second sampler, use the transformer from that sampler to charge the batteries.</p> <p>2) Disassemble the battery case using a Phillips screwdriver and connect the battery charger board to another battery. If the same condition results, the battery charger board is defective. If the battery LED lights and the new battery charges, the previous battery is defective.</p>

The battery charger light on the battery top does not turn off after overnight charge.

The battery may be defective, as indicated by the charger light remaining on "high charge" (*i.e.*, the battery fails to hold the charge and the charger continues to charge). Connect a new battery to the battery charger board. If the same condition results, the charger board is defective. If the light turns off, the previous battery is defective.

Battery voltage is less than 12 volts after charging or the battery will not power the sampler for a 24hr run.

1) Check the battery by connecting a volt-ohm meter (VOM) to the negative and positive battery terminals located on either side of the battery charger light (the negative terminal is odd colored and located next to the sampler catch). If there is no voltage or the VOM readings are intermittent, check that the terminals on the battery cover are tight. If not, see next step.

2) If there is still a voltage problem, remove the battery pack top using a Phillips screwdriver and look for loose connections. The battery charger board should be securely clamped to the banana jacks and connected securely to the battery. Tighten and clean any connections if corroded. Check the battery charging jack for a snug fit with the charging transformer plug. Connect the meter directly to the internal battery terminals. If there is still no or low voltage, see step 3.

NOTE: if loose or corroded connections were found make sure the battery has received a full charge before proceeding with the next step.

3) Even if the VOM meter indicates the correct voltage, perform the following check. Connect a 12-volt light (such as a automobile headlight) to the battery to simulate a load. Monitor the battery voltage while connected to the simulated load. The battery voltage should drop and stabilize somewhere between 11.5 and 12 volts. When the simulated load is disconnected the voltage should return to approximately 12.5 volts (within ± 0.2 volt). If the battery fails to stabilize or does not recover to about 12.5 volts, the battery is most likely defective.

NOTE: make sure when performing these tests the battery is charged and disconnected from the transformer.

The flow rate cannot be accurately adjusted using the Flow Rate Adjustment.

The pump valves and diaphragms are dirty or worn and need cleaning or replacing (see Section 7, Maintenance, "Cleaning/Replacing Pump Valves and Diaphragms").

Check the pulse dampener for cracks.

The flowmeter will not register a high flow rate (6 lpm or above). There is no apparent restriction or leak in the plumbing.

The pump valves and diaphragms are dirty or worn and need cleaning or replacing (see Section 7, Maintenance, "Cleaning/Replacing Pump Valves and Diaphragms").

Check the pulse dampener for cracks.

Bags do not fill consistently or significant adjustments to frequency or pulse duration have minimal effect.

The solenoid valve is leaking. The performance of the solenoid valve can be determined by placing a clear piece of tube from the outlet fitting into a few inches of water and watching for any back flow of water into the tube between pulses. If any backflow is present , check that the fittings are tight. If the problem persists, contact Airmetrics.

This page was intentionally left blank.

A SAMPLER FLOW RATE CALIBRATION

The MiniVol Portable Air Sampler is designed to operate at 5 lpm at ambient conditions. At the factory the sampler is calibrated at approximately 21°C at 754 mm Hg, and is adjusted to operate at 5 lpm at these conditions. (See calibration curve shipped with sampler.) In other localities, the sampler must be adjusted to account for the different ambient temperature and barometric pressure. Adjustment within a range previously established by calibration is usually performed before every sampling project. This appendix explains how to use the calibration information shipped with the MiniVol to determine the flow rate that will equal 5 liters/minute at local ambient conditions.

In the calibration procedure used by Airmetrics, the flowmeter is calibrated against a Laminar Flow Element (LFE) flow measuring device. Six flow rates, ranging from approximately 4 to 6 liters/minute, are typically measured. The inlet of the LFE is open to the atmosphere while the outlet is attached to the inlet of the sampler. (The sampler's filter assembly is not included in the air stream during the calibration procedure.)

Figure A.1 shows the results of a typical MiniVol calibration.

The columns in the table in Figure A.1 are defined as:

Q_{ind} Flowrate as indicated by the rotameter on the sampler.

Q_{act} Flowrate at the actual calibration conditions as determined from the LFE.

Q_{@std} The flowrate at standard conditions for the indicated LFE pressure drop. (Note that this is not the same as converting the actual flow rate to standard conditions.) Standard conditions are defined as an atmospheric pressure (**P_{std}**) of 760 millimeters of mercury and a temperature (**T_{std}**) of 298°K.

Q_{calc} The calculated flowrate of the sampler that is determined from the linear regression results.

Diff The percentage difference in flow rates between the measured and the calculated flow rates.

For each point in the calibration procedure, the flow rate indicated by the flowmeter, "Q_{ind}", is recorded, and the actual flow rate, "Q_{act}" and "Q_{@std}" are calculated from the pressure drop across the LFE.

The flow rate units "lpm" are liters per minute.

The **Linear Regression Results** in Figure A.1 shows the results of the best fit line of Q_{ind} (independent) to Q_{@std} (dependent) variables:

$$Q_{@std} = m_{vol} \times Q_{ind} + b_{vol} \quad (1)$$

where **m_{vol}** = slope of the least square line
b_{vol} = intercept the least square line

The variance (**r²**) is also listed in Figure A.1.

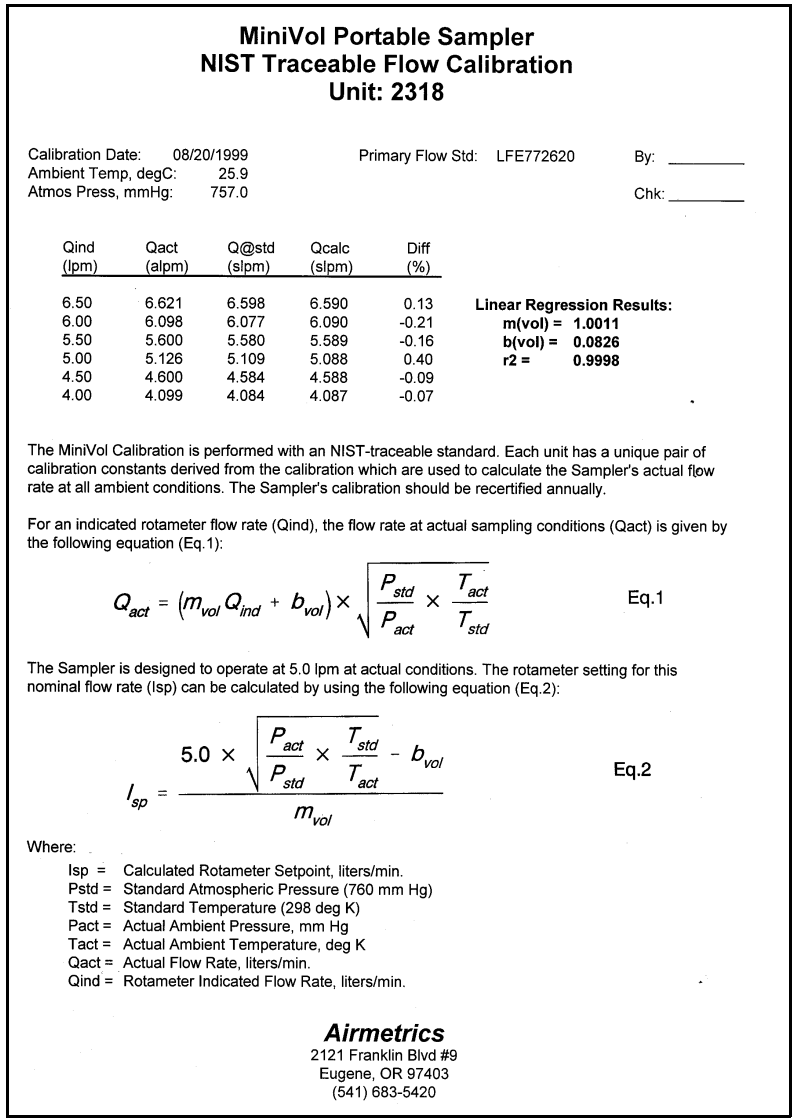

Figure A.1. Portable Sampler Calibration Output

Sampling at Ambient Conditions

The MiniVol's size-selective inlet is an impactor whose particle size selection characteristic is dependent upon the velocity with which the air stream impacts upon the impaction plate. The impactor is designed to have a nominal 10µm (part 206-000) or 2.5µm (part 206-100) cut off at an actual air flow rate of 5.0 liters per minute. To maintain this cut off size, the sampler's flow rate must be adjusted (flowmeter set point - I_{sp}) so that the flow rate through the size-selective inlet is maintained at 5.0 lpm at **ambient** conditions.

To calculate the flowmeter set point, you need:

- the sampler's calibration slope, m_{vol} , and intercept, b_{vol} . This information is supplied to you on the "MiniVol Portable Sampler NIST Traceable Flow Calibration" that came with your sampler (Figure A.1);
- the expected ambient temperature, T_{act} , in K°, and pressure, P_{act} , in mm Hg, expected during the sampling study. This data may be estimated from local weather service data or from other reported historical data. If the U.S Weather Service atmospheric pressure is used, be sure that the "station pressure" is used. That is, atmospheric pressure **not** corrected for the reporting site's elevation above sea level.

If the local "station pressure", P_{act} is not readily available, it can be reasonably estimated by using Equation 2.

$$P_{act} = P_{sea} \times \left(1 - \frac{E}{145330} \right)^{5.25} \quad (2)$$

Where P_{act} = ambient atmospheric pressure
 P_{sea} = sea level atmospheric pressure (nominally 760 mm Hg)
 E = site elevation in feet

The Flowmeter Set Point, I_{sp} , is calculated using Equation 3.

$$I_{sp} = \frac{5.0 \times \sqrt{\frac{P_{act}}{P_{std}} \times \frac{T_{std}}{T_{act}}} - b_{vol}}{m_{vol}} \quad (3)$$

Where I_{sp} = flowmeter set point, liters/minute
 P_{std} = standard atmospheric pressure, 760 mm Hg
 T_{std} = standard temperature, 298 K°
 P_{act} = actual ambient pressure, mm Hg
 T_{act} = actual ambient temperature, K°

PM Concentration Calculation

To calculate the PM concentration for a sample taken with the MiniVol sampler, the volume of air that passed through the filter at standard conditions, V_{std} , or at ambient conditions, V_{amb} , must be calculated. This is most easily done in a multi-step procedure (the example that follows uses Sampler 2318 whose calibration sheet is shown in Figure A.1):

1. Calculate the air flow rate at ambient conditions, Q_{act} , using Equation 4. The slope, m_{vol} , and intercept, b_{vol} , of the sampler calibration are obtained from the calibration sheet. For Sampler 2318, $m_{std} = 1.0011$ and $b_{std} = 0.0826$. The units of Q_{std} are *liters/minute*.

$$Q_{act} = (m_{vol} \times Q_{ind} + b_{vol}) \times \sqrt{\frac{P_{std}}{P_{act}} \times \frac{T_{act}}{T_{std}}} \quad (4)$$

2. Calculate the volume of air that passed through the filter during the sampling period at actual ambient conditions, V_{act} (in cubic meters).

$$V_{act} = \frac{60 \text{ min/hr} \times Q_{act} \times t_{hr}}{1000 \text{ l/m}^3} \quad (5)$$

where t_{hr} = sampling period, in hours

In the equation above, time is expressed in hours since the MiniVol's elapsed time meter records time in hours. The units of V_{act} are *cubic meters*.

In the actual use of the portable samplers, the *temperatures, pressures and flowmeter readings* are only noted at the start (when the sampler is set up for a run) and end (when sampler is retrieved) of the sampling period. Therefore, calculate Q_{act} for the starting and ending conditions and use the average Q_{act} to determine V_{act} .

3. To calculate the concentration at standard conditions, correct the volume of air at actual ambient conditions, V_{act} , to the volume of air at standard conditions, V_{std} :

$$V_{std} = V_{act} \times \left(\frac{P_{act}}{P_{std}} \right) \times \left(\frac{T_{std}}{T_{act}} \right) \quad (6)$$

4. To finally calculate the concentration of PM, divide the net mass gain of the filter by the volume of air that passed through the filter.

$$[PM]_{act} = \frac{M_{PM}}{V_{act}} \quad (7)$$

or

$$[PM]_{std} = \frac{M_{PM}}{V_{std}} \quad (8)$$

where $[PM]_{act}$ = PM concentration, in μ grams per cubic meter (actual)
 $[PM]_{std}$ = PM concentration, in μ grams per cubic meter (standard)
 M_{PM} = Mass of particulate matter collected on the filter, in μ grams

B QUICK REFERENCE

Particulate Matter Sampling Routine at Site

Note: Perform as much work as possible inside a vehicle (disassembling sampler, checking for leaks, replacing filter, *etc.*), particularly if the weather is rainy, windy, or snowy.

1. Hoist the sampler down from the mounting cradle, keeping the hoisting pole as vertical as possible to avoid dropping the sampler or damaging the preseparator/filter holder assembly with the hook.
2. Inside the vehicle, remove the bale bar assembly and handle.
3. Remove the timer and pump assembly by grasping the 6" lid, taking care not to disconnect power cord from battery. Do NOT grasp center of circuit board. Mount the assembly on the edge of the sampler casing using the pump mount stand. Leave the battery attached.
4. Record the hours shown on the elapsed time totalizer.
5. Press the Timer On/Auto/Off button to start pump.

Error: If a RED LIGHT is lit (either low flow or low battery), press the Reset button to start pump.

6. With the sampler held vertically, read the flowmeter (to the nearest tenth at center of ball) and record the ending flow rate.
7. Lower assembly back into tube.
8. Before removing the preseparator/filter holder assembly from sampler, cross-check the filter sticker number on the assembly against the filter number for that site on the worksheet. These numbers should match. If not, make a note of this, recording the actual filter number.
9. Remove the preseparator/filter holder assembly at the quick-connect and place it in clean plastic bag for transport back to lab.
10. Change the battery pack. (Do not inadvertently confuse and reuse the spent battery.) If either the low or low voltage indicator was lit, make a note that the spent battery may be defective.
11. Check the sampler for leaks. Remove the pump and timer assembly from the sampler body, start the pump by pressing the On/AUTO/Off button, and cover the inlet with palm. The ball should drop to the bottom of the flowmeter. If it does not, check/tighten all tubing, joints, and quick-connect fittings until the sampler is leak-free.
12. Attach a new preseparator/filter holder assembly containing a new filter at the sampler quick-connect.
13. If the low flow indicator was lit, check for crimps or air restrictions in the inlet or tubing.
14. On a new Field Data Log worksheet, record site #, sampler #, battery #, and new filter #.
15. With the sampler running and while holding it vertically, adjust the flow rate to the correct level. Record the beginning flow rate to the nearest tenth of liter/minute.
16. Turn the pump off by pressing ON/AUTO/OFF button.

17. Record hours shown on the Elapsed Time Totalizer.
18. Program the Programmable Timer.
19. Lower the pump and timer assembly into the sampler body and reinsert the bale assembly bar..
20. Return the sampler to the mounting cradle, raising it as vertically as possible.
21. If also doing gas sampling, see the following Integrated Gas Sampling Routine.

Integrated Gas Sampling Routine At Site

Note: Perform as much work as possible inside a vehicle (disassembling sampler, replacing canisters, *etc.*), particularly if the weather is rainy, windy, or snowy.

1. Lower sampler from its cradle mount, keeping the hoisting pole as vertical as possible to avoid dropping the sampler or damaging the preseparator/filter assembly with hook.
2. Inside the vehicle remove the bale bar assembly. Detach canister tubing at the mini quick-connect fittings and remove canisters.
3. Remove the pump and timer assembly, taking care not to pull the connecting wire loose. Hold the top cap. Do NOT grasp the circuit board. Mount the assembly on the sampler casing using the triangular mount stand.
4. Verify correct time and day of week on time LCD.
5. Record elapsed time as shown on the Elapsed Time Totalizer, which should match the programmed time.
6. Check and record the fullness of the bag(s), adjusting the pulse interval or duration if necessary.
7. Program the timer for new sampling period (see page 5).
8. Set to "Auto" mode.
9. Change battery pack (see page 17).

IMPORTANT NOTE: The Valve Driver Board automatically resets when the sampler's main power is interrupted. This is why the battery must be changed *before* setting the sequencing circuit.

10. Check the Active Solenoid Output Indicators. Use the Manual Sequence Advance Button to select the required channel if necessary.
11. Lower the pump and timer assembly into the sampler body.
12. Replace the bale bar assembly, attach new canisters, and connect tubing.
13. Return the sampler to the mounting cradle, raising it as vertically as possible.
14. If also doing particulate matter sampling, see the preceding Particulate Matter Sampling Routine.

C WARRANTY POLICY

What is Covered

The MiniVol Portable Air Sampler is warranted by Airmetrics against defects in materials and workmanship for one year from the date of original purchase. If you sell your unit or give it as a gift, the warranty is automatically transferred to the new owner and remains in effect for the original one-year period. During the warranty period, we will repair or, at our option, replace at no charge a sampler that proves to be defective, provided you return the sampler, shipping prepaid, to Airmetrics. (Replacement may be with a newer model of equivalent or better functionality.)

This warranty gives you specific legal rights, and you may also have other rights that vary from state to state, province to province, or country to country.

What is Not Covered

AA batteries, and damages caused by AA batteries, are not covered by the Airmetrics warranty.

This warranty does not apply if the product has been damaged by accident or misuse or as the result of service or modification by other than an Airmetrics technician.

No other express warranty is given. The repair or replacement of a product is your exclusive remedy. Any other implied warranty of merchantability or fitness is limited to the one-year duration of this written warranty.

Some states, provinces, or countries do not allow limitations on how long an implied warranty lasts, so the above limitation may not apply to you. In no event shall Airmetrics be liable for consequential damages. Some states, provinces, or countries do not allow the exclusion of limitation of incidental or consequential damages, so the above limitation or exclusion may not apply to you.

Warranty on Service

Service is warranted against defects in materials and workmanship for 90 days from the date of service.

Service Agreements

In the US., a support agreement is available for repair and service. For additional information, contact:

Airmetrics
2121 Franklin Boulevard, #9
Eugene, Oregon 97403
U.S.A.
(541) 683-5420

This page was intentionally left blank.

D REPLACING DAMAGED/DEFECTIVE COMPONENTS

In the event that a MiniVol Portable Air Sampler component is missing, damaged, or defective, follow these steps to obtain a replacement part:

- Call Airmetrics tech support and explain the problem. . . .(541) 434-9695.
- Obtain authorization to return the defective or damaged components.
- Package the item(s) carefully to prevent further damage.
- Identify the item(s) being returned on a clearly marked packing list with your name, company name, address, and phone number.
- Ship to our shop address:

Airmetrics
2121 Franklin Blvd., #9
Eugene, OR 97403
U.S.A.
(541) 683-5420

- Items will be repaired/replaced and returned as soon as possible.

This page was intentionally left blank.

E PARTS LIST

The following Figures and Tables identify the components and parts of the MiniVol sampler.

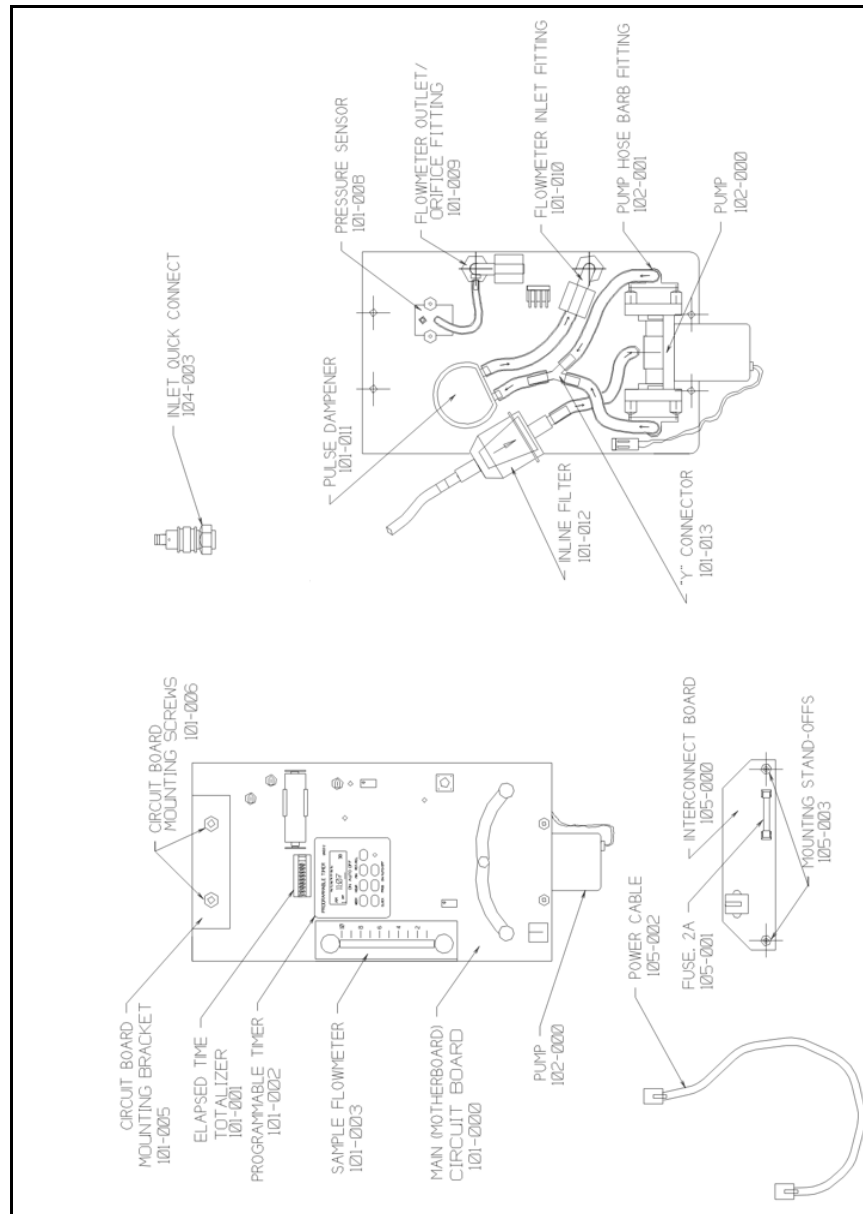

Figure F.1. Main Circuit Board Parts Identification.

Main Circuit Board Card (see Figure F.1)	
P/N	Description
101-000	Main Circuit Board Card (w/o Pump and Flowmeter)
101-001	Elapsed Time Totalizer
101-002	Programmable Timer
101-005	Mounting Bracket
101-008	Pressure Sensor
101-009	Flowmeter Outlet/Orifice Fitting
101-010	Flowmeter Inlet Fitting
101-011	Pulse Dampener
101-012	Inlet Filter
101-013	Plastic Y-connector, 3/16"
101-003	Flowmeter, 0-10 LPM
102-000	Pump, Dbl Diaphragm, 8-12 V
102-001	Pump Hose Barb Fitting, 1/4-28 × 3/16" ID Hose
102-002	Pump Mounting Bracket
102-006-N	Pump Rebuild Kit, 2-head
102-006-01	Pump Diaphragm, Neoprene
102-006-02	Pump Valve
102-006-03	Pump Valve Seat, Viton
102-006-04	Pump Valve O-Ring, Silicone
101-019	Pump Mount Stand, Aluminum

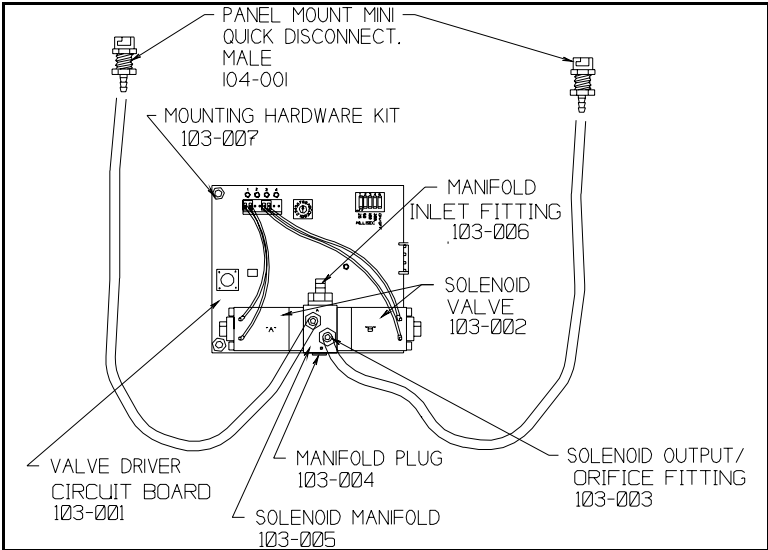

Figure F.2. Valve Driver Board Parts Identification

Valve Driver Board (see Figure F.2)	
P/N	Description
103-000	Complete Valve Driver Board
103-001	Valve Driver Circuit Board
103-002	Solenoid Valve
104-001	Panel Mount Mini Quick Connect, male
104-011	Female Mini Quick Connect

This page was intentionally left blank.

Sampler Case External Hardware/Power Interconnect	
P/N	Description
104-002	SS, Bolt, 1/2-13 x 3/4"
104-003	Male Quick Connect Inlet Fitting
104-004	Battery Pack Mounting Latch
104-005	Banana Plug
104-006	SS, Hex Nut, 1/2-13
105-000	Interconnect Board
105-002	Power Cable
105-004	Plated Brass Standoff, 6-32 x 1/2" M/F
106-000	Bale Handle, Complete

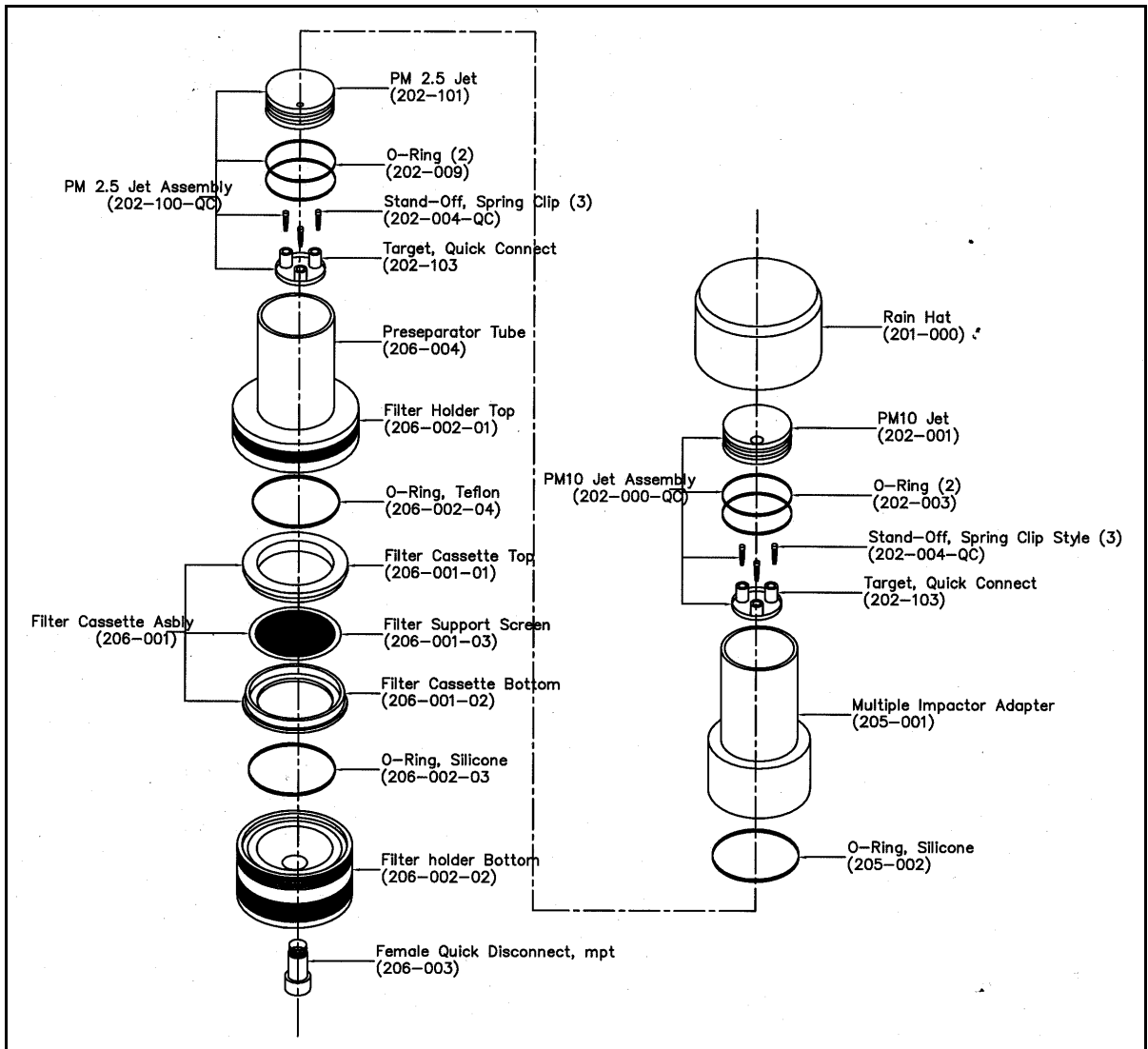

Figure F.4. Preseparator and Filter Parts Identification

Preseparator and Filter Holder Assembly (see Figure F.4)	
P/N	Description
206-000	PM ₁₀ Preseparator/Cassette Filter Holder Assembly, Complete
206-100	PM _{2.5} Preseparator/Cassette Filter Holder Assembly, Complete
206-001	Filter Cassette, FRM Style, Complete
206-001-03	Filter Support Screen/drain disk
206-002	Filter Holder Assembly, Grey, no tube, disconnect
206-002-01	Filter Holder, Top
206-002-02	Filter Holder, Bottom
206-002-03	O-Ring for Top, Teflon
206-002-04	O-Ring for Bottom, Viton
206-003	Quick Disconnect, 1/4" mpt, female
206-004	Preseparator Tube, Grey
201-000	PVC Rain Hat
202-000-QC	Impactor, PM ₁₀ , QC, Complete
202-001	Jet, PM ₁₀
202-004-QC	Stand-Off, Spring Clip Style
202-103	Impaction Plate, Quick Connect
202-003	O-Ring, PM ₁₀ , Silicone, Red
202-100-QC	Impactor, PM _{2.5} , QC, Complete
202-101	Jet, PM _{2.5}
202-004-QC	Stand-Off, Spring Clip Style
202-103	Impaction Plate, Quick Connect
202-003	O-Ring, PM _{2.5} , Silicone, Red
205-001	Multiple Impactor Adapter, Grey
205-002	O-Ring for Adapter

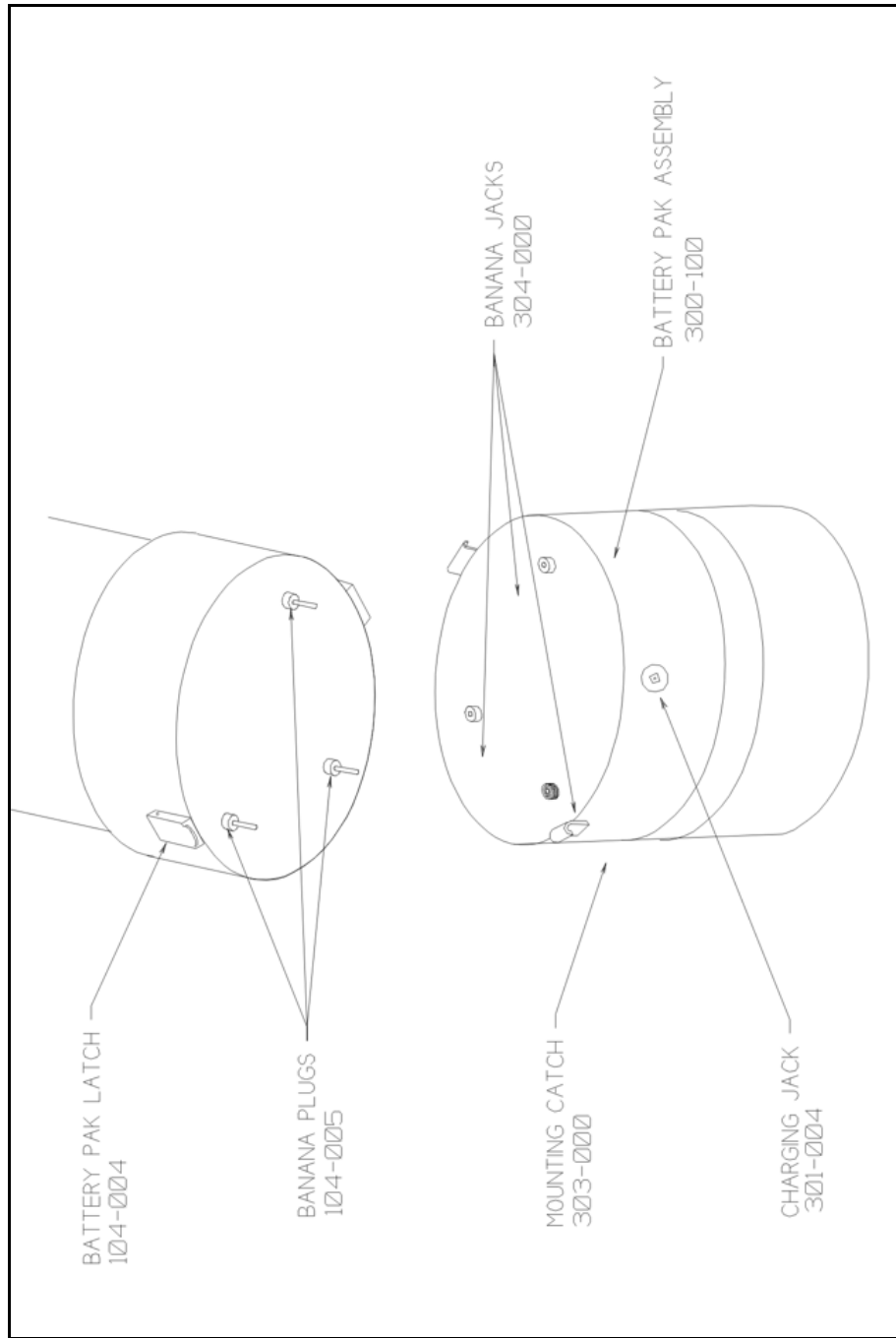

Figure F.5. Battery Pack Parts Identification

Battery Pack Assembly (see Figure F.5)	
P/N	Description
300-000	Battery Pack Assembly
303-000	Mounting Catch
304-000B	Banana Jack, Black
304-000R	Banana Jack, Red
301-000A	Battery Charger, 12 VDC

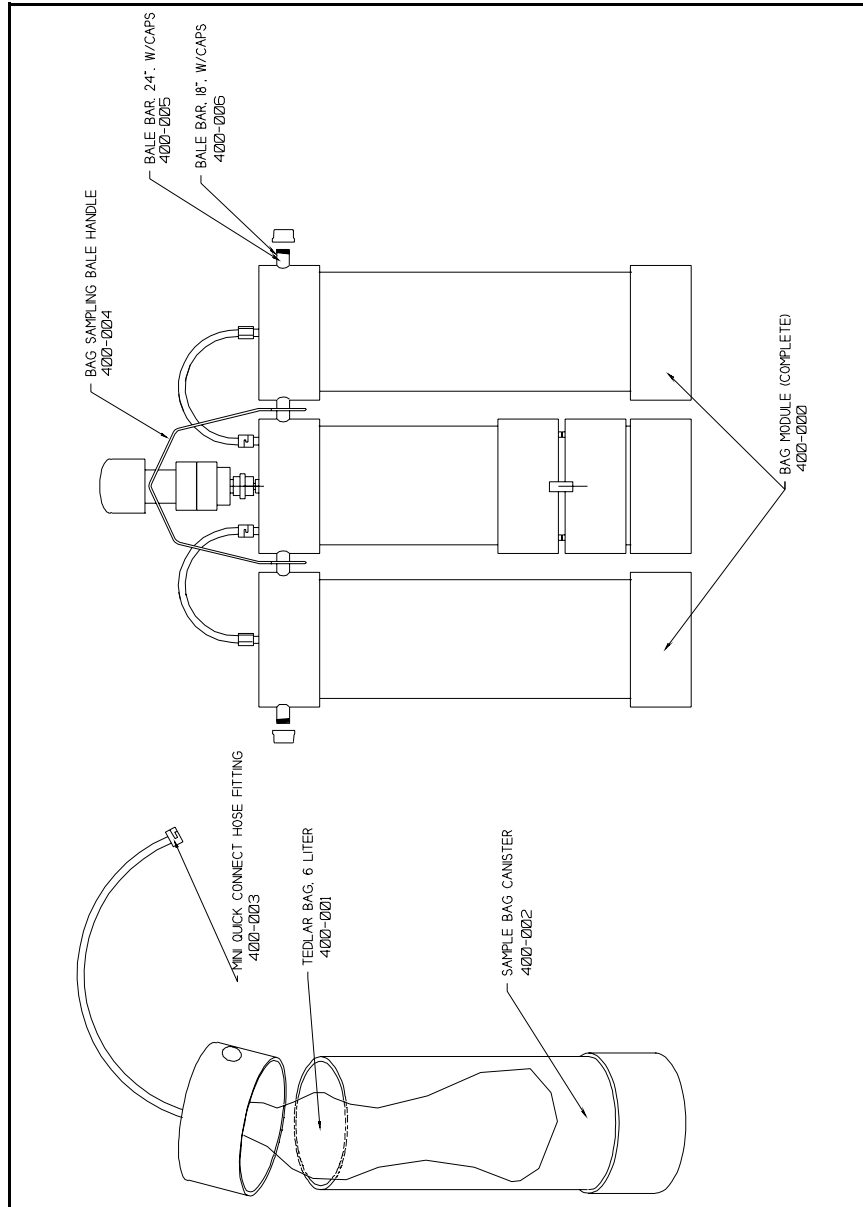

Figure F.6. Integrated Gas Sampling Bag Parts Identification

Integrated Gas Sampling Bag Assembly (see Figure F.6)	
P/N	Description
400-000	Complete Bag Module
400-001	Tedlar® Bag, 5 liter
400-003	Mini Quick-Connect Hose Fitting
107-000	Bag Sampling Bale Handle
400-005	Bale Bar, 24", PVC
400-006	Bale Bar, 16", PVC
400-010	Bag evacuation Fitting

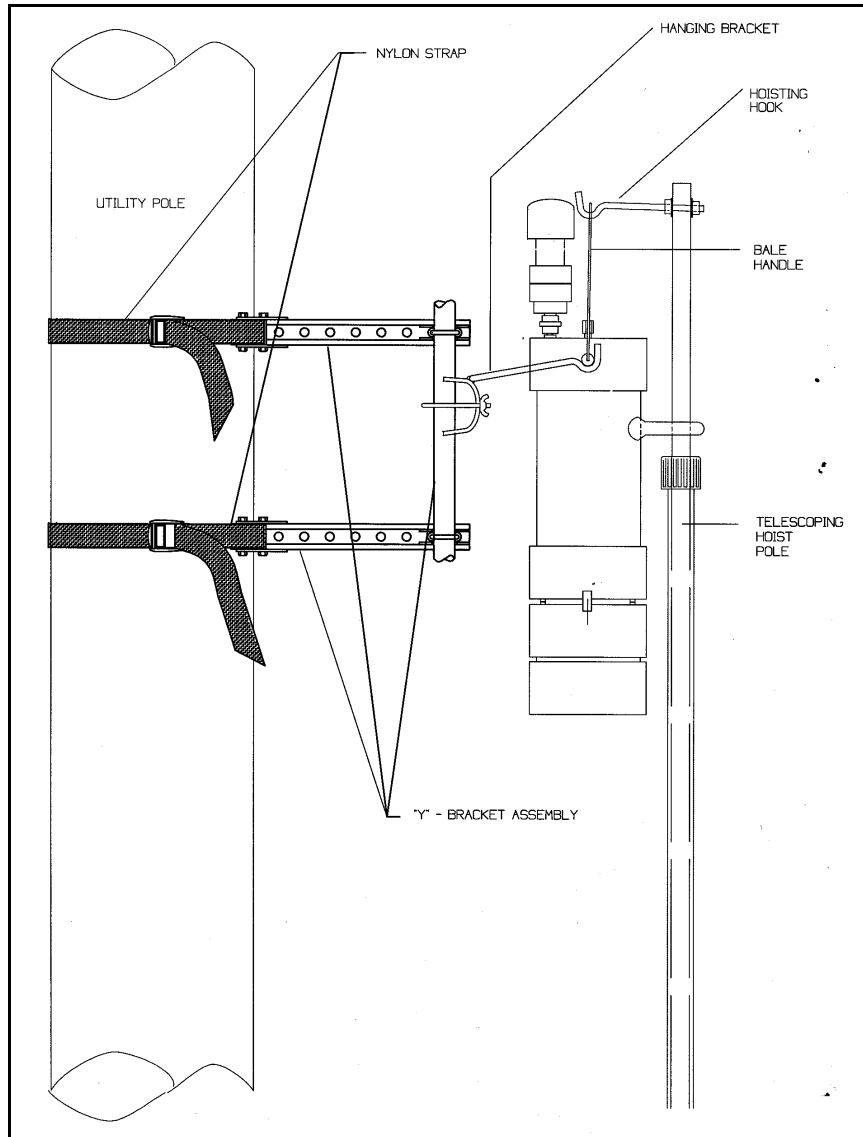

Figure F.7. Mounting Hardware Parts Identification

Mounting Hardware (See Figure F.7)	
P/N	Description
501-000	Complete Telescoping Hoisting Pole Assembly
501-001	Telescoping Fiberglass Pole
501-002	Pole Hook
502-000	Mounting Cradle
504-000	Y-Bracket Assembly (Complete)
600-000	Tool Box, 9" x 119" x 20"
600-001	Operating Manual

Miscellaneous Parts	
P/N	Description